

Voltage and Frequency Relay UFR1002IP

Grid- and Plant Protection VDE-AR-N 4105, 4110, 4120, NA-Box
IP interface and LCD-Display

UFR1002IP

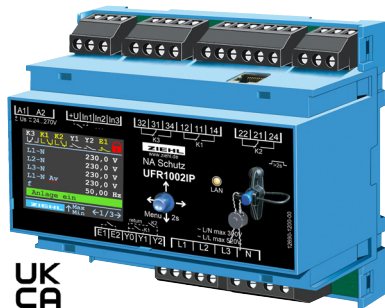

UK
CA

Part numbers:

UFR1002IP **S222301**

ER6 **T224386**

VG1200 **S222312**

Approvals/certificates:

Germany:

- Certificate of conformity Grid- and Plant protection acc. to VDE-AR-N 4105:2018-11 "Plants for generation of own energy in low voltage grid"
- Certificate for component VDE-AR-N4110 and 4120

Great Britain:

- Certificate of compliance G98/1-7:2022 and G99/1-9:2022

Austria:

- Clearance Certificate TOR Producer Type A and TOR Producer Type B

Sweden nät och systemskydd:

- Certificate of compliance EN 50549-1:2019. EN 50549-2:2019

The grid decoupling relay UFR1002IP is the "big brother" of the UFR1001E and monitors voltage and frequency in three-phase and AC grids.

With a color LCD display (German/English) and joystick, it is even easier to operate than the UFR1001E. Measured values and settings are clearly displayed. The device can be programmed, updates installed and the alarm memory read out via the integrated IP interface. The real-time clock (with power reserve) simplifies the traceability of the alarms. Up to 1,200 V can be monitored in conjunction with the VG1200 coupling device.

Features:

- single-fault-proof, with monitoring of connected switch (can be switched off when using the integrated switch of PV and battery converters)
- Programmable restart attempts in the event of a switch-on error in the connected switch
- Relay K3 with programmable functions, including life contact, delayed switch-on signal for switches or error messages

The device has a two-channel, single-fault-safe design and thus meets the requirements of VDE-AR-N 4105:2018-11. The function of the connected switch is monitored. If monitoring is activated, the device does not switch on again if a switch-off error is detected.

Limit values for different applications are preset. Where permitted, they can easily be changed. If the nominal voltage is changed, the device automatically adjusts the limit values that have already been set.

With the standby input, a remote shutdown can be implemented, e.g. with a ripple control receiver.

Monitoring of:

- Under/over voltage 15-520V (with ZIEHL VG1200 coupling device up to 1,200 V)
- Under/over frequency 45-65 Hz
- Voltage quality (10-minute average)
- Vector shift 2-65°
- ROCOF, rate of change of frequency df/dt 0.100...5.000 Hz/s
- Zero voltage U_0 (ANSI 59v0)
- passive anti islanding protection

- Response time adjustable 0.05 ... 300,0 s
- Switch-back time adjustable 0 ... 6,000 s
- Preset according to VDE-AR-N 4105-2018-11 (Pr1.02, Pr. 1.08 + 1.09) and VDE-AR-N 4105-2011-08 (Pr 1.01)
Preset according to VDE-AR-N 4110-2018-11
- (Pr 1.11-1.14) and bdev guideline (Pr 1.03-1.06) automatic adjustment of the switching points when the nominal voltage is changed
- Alarm counter for 100 alarms (with trigger value, cause and date/time, time of restart)
- 3 programmable digital inputs
Standby counter and timer with standby on/off date/time
- Test and simulation function with measurement of switch-off times
- Sealing option and code protection for settings
Interface ethernet TCP/IP, values available via modbus TCP
- Simple commissioning and programming thanks to preset basic programs and transmission via IP interface
- Supply voltage AC/DC 24-270 V
Housing for DIN-rail mount, 105 mm wide, installation depth 66 mm

Accessory: [Installation frame ER6 for panel mount](#)
[ZIEHL Coupling device VG1200](#)

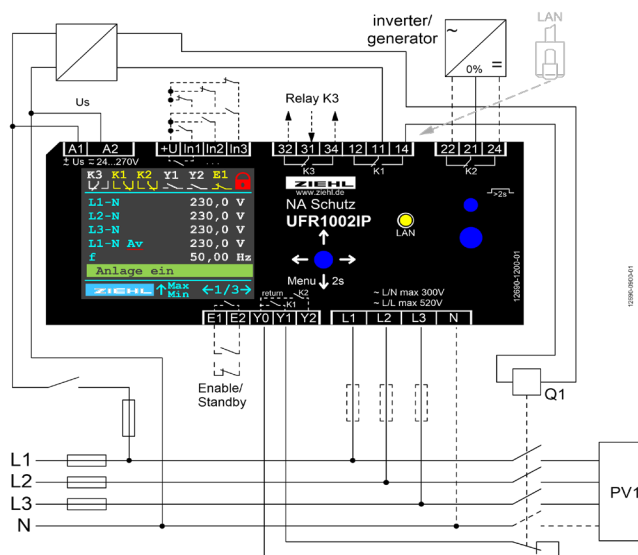

Technical Data UFR1002IP

Power supply	Rated supply voltage Us	AC/DC 24-270 V, 0/50/60 Hz, <4,5 W, < 12,5 VA
	bridging at dropping Us	DC: 20,4...297 V, AC: 20,4...297 V 230 V -> 0 V: 1,2 s
Relay output		3 change over contacts, see operating manual
Voltage	Measurement phase-phase	AC 15...530 V (< 5 V display 0)
	Measuring voltage phase-neutral	AC 10...310 V (< 5 V display 0)
	Setting range	AC 15...520 V
	Measurement method	true RMS
	Measurement accuracy	≤0,8 % of nominal voltage
	Measurement functions	3-phase with / without neutral
	Switching-delay (dAL)	adjustable 0,05 (± 15 ms)...300,0 s
	Switching-back-delay (doF)	adjustable 0 (> 200 ms)...6.000 s
	Input resistance phase - phase and phase - N	993 kΩ
Frequency	Measurement range	40...70 Hz
	Setting range	45,00...65,00 Hz
	Measurement accuracy	± 0,05 Hz
	Switching delay (dAL)	adjustable 0,05 (± 15 ms)...300,0 s
	Switching-back-delay (doF)	adjustable 0 (> 200 ms)...6.000 s
ROCOF (df/dt)	Setting range	0,100...5,000 Hz/s, 4...50 cycles
Digital outputs insulated	E1/E2, Y0...Y2, In1...In3	DC 15...35 V
Test Conditions		IEC/EN 60255
	Rated impulse voltage	4000 V
	Overtoltage category	III
	Pollution degree	2
	Rated Insulation voltage Ui	300 V
	Operating time	100 %
	Operating temperature	-20 °C...+55 °C
	Storage temperature	-25 °C...+70 °C
	Climatic conditions (IEC/EN 60721-3-3)	3K5 (except condensation and formation of ice)
	EMC - immunity	EN 61 000-6-2
EMC - emission	EN 61 000-6-3	
Housing	Design / Installation Frame	V6 / Front mounting kit type ER6
	Dimensions (h x w x d)	90 x 105 x 69 mm, mounting height 55 mm
	Protection housing/terminals	IP30/20
	Attachment	DIN rail 35 mm according to EN 60 715 or screws M4
	Weight	approx. 290 g