

# Operating Manual PSSW1

updated: 2023-07-04 / dr



For more information and help about this product please scan the [QR-Code](#) or choose the following link: [PSSW1](#)

Operating manual, Quick guide, Datasheet, Connection diagram, CAD Data  
Firmwareupdates, FAQ, Videos about installation and settings, Certificates

- Three-phase current monitor for phase symmetry, phase sequence, undervoltage and overvoltage



## Table of contents

1	General Notes .....	2
2	Display and controls .....	2
3	Application and short description.....	2
4	Overview of functions .....	3
5	Connecting diagram .....	3
6	Function Chart.....	3
7	Important Information .....	4
8	Installation .....	4
9	Commissioning.....	4
10	Error search .....	5
11	Technical data .....	5
12	Housing Type K.....	7
13	Disposal .....	7

## 1 General Notes

Compliance with the following instructions is mandatory to ensure the functionality and safety of the product. If the following instructions given especially but not limited for general safety, transport, storage, mounting, operating conditions, commissioning and disposal / recycling are not observed, the product may not operate safely and may cause a hazard to the life and limb of users and third parties.

Deviations from the following requirements may therefore lead both to the loss of the statutory material defect liability rights and to the liability of the buyer for the product that has become unsafe due to the deviation from the specifications.

## 2 Display and controls

- 1) Potentiometer  $\langle \rangle U$ : Adjustment of the undervoltage/overvoltage of 2...20%
- 2) potentiometer Asy: Adjustment of the asymmetry of 5...15%
- 3) Potentiometer t: Setting the delay time of 0.1...12s
- 4) LED  $\langle \rangle U$ : lights up in case of overvoltage, flashes in case of undervoltage
- 5) LED Asy: lights up during phase asymmetry
- 6) LED Ph: lights up in case of phase failure, flashes in case of incorrect phase sequence
- 7) LED Rel: illuminates when relay ON (11,14 closed)

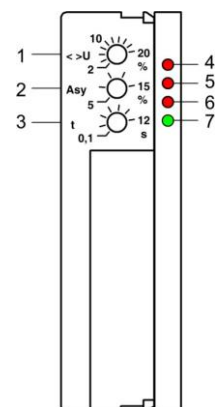

## 3 Application and short description

Three-phase current monitors of the type PSSW1 monitor three-phase networks for phase symmetry, phase sequence, undervoltage and overvoltage, thus protecting motors from damage and ensuring a longer service life.

Examples of applications are the monitoring of three-phase power grids on construction machines, compressors or heat pumps.

## 4 Overview of functions

- Undervoltage and overvoltage adjustable  $\pm 2 \dots 20\%$  (common)
- Asymmetry adjustable  $\pm 5 \dots 15\%$
- Phase failure
- Delay time adjustable 0.1 ... 12s (for voltage and asymmetry)
- Bifrequency measurement input 50/60Hz

## 5 Connecting diagram

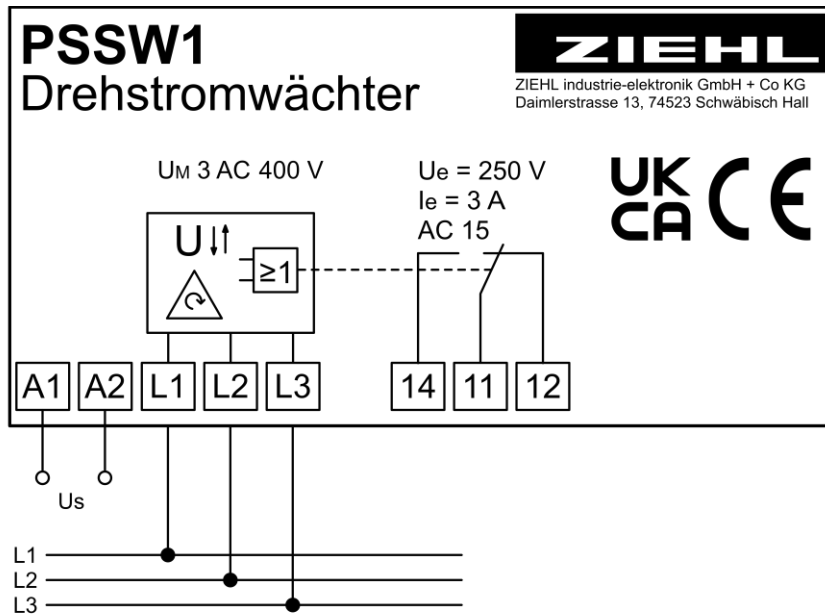

## 6 Function Chart

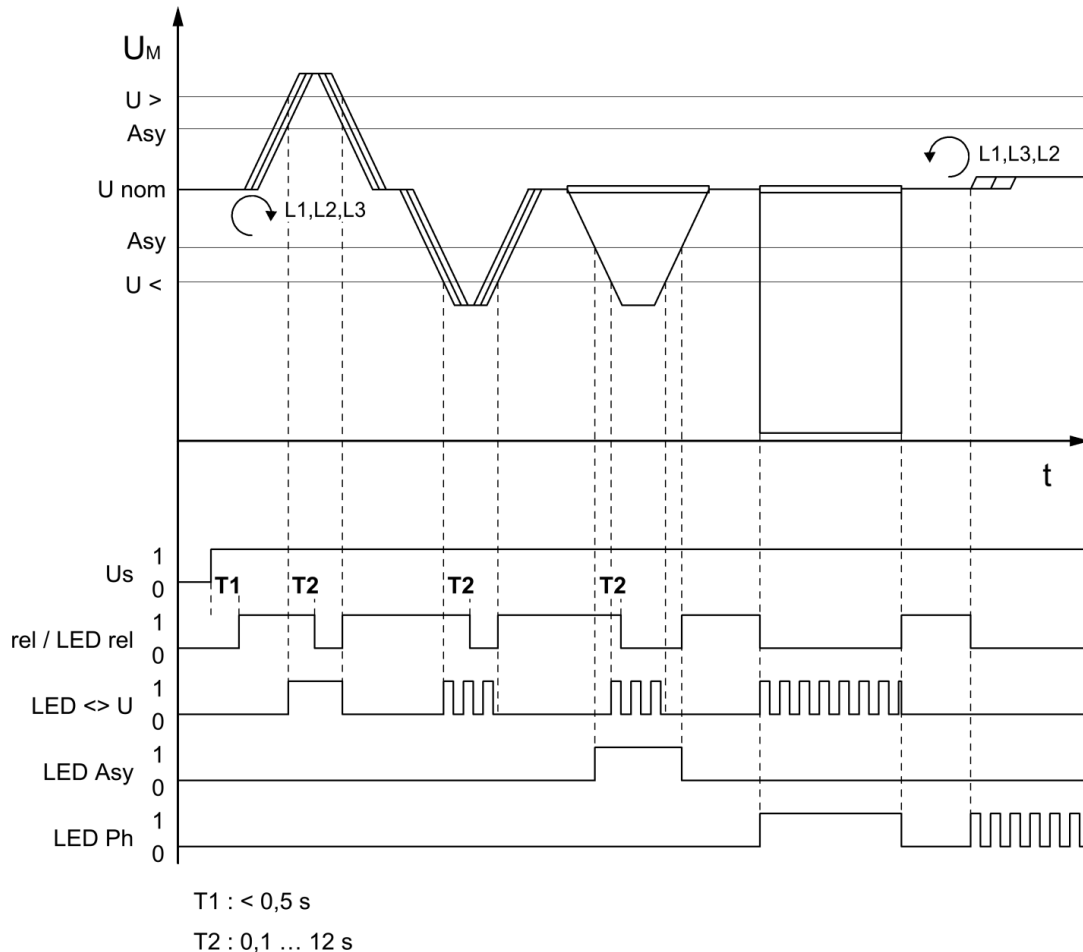

## 7 Important Information



### **DANGER!**

**Hazardous voltage!**

**Will cause death or serious injury. Turn off and lock out all power supplying this device before working on this device.**



### **Attention!**

**The protective function of the device is only ensured if the wiring is carried out directly into the control circuit of the work equipment according to the connection diagram. The relay contacts must be secured externally in order to prevent welding.**

To use the equipment flawless and safe, transport and store properly, install and start professionally and operate as directed.

Only let persons work with the equipment who are familiar with installation, start and use and who have appropriate qualification corresponding to their function. They must observe the contents of the instructions manual, the information which are written on the equipment and the relevant security instructions for the setting up and the use of electrical units.

The equipment is built according to DIN VDE/EN/IEC and checked and leave the plant according to security in perfect condition. If, in any case the information in the instructions manual is not sufficient, please contact our company or the responsible representative.

In order to maintain this status, you must observe the safety regulations entitled "caution" in this operating manual. Failures to follow the safety regulations can result in death, personal injury or property damage to the device itself and to other devices and facilities.

To maintain this condition, you must observe the safety instructions in this instruction manual titled "Important Information". Failure to follow the safety instructions may result in death, personal injury, or property damage to the equipment itself and other equipment and facilities.

Instead of the industrial norms and regulations written in this instruction manual valid for Europe, you must observe out of their geographical scope the valid and relevant regulations of the corresponding country.

## 8 Installation

- mount on 35 mm mounting rail according to EN 60715
- wall-mount with 3 x screws M4
- connecting wires refer to the connection plan to prevent miss-operation and malfunction.



**Observe the maximum permissible temperature when installing in the control cabinet. It is necessary to ensure sufficient distance to other devices or heat sources. If the cooling is made more difficult, for example by the close proximity of devices with increased surface temperature or obstruction of the cooling air flow, the permissible ambient temperature is reduced.**

## 9 Commissioning



### **Attention!**

**Before connecting the device, make sure that the control voltage  $U_s$  on the side type plate of the device and the mains voltage match!**

- Carry out the connection according to the connection diagram or type plate.
- In normal operation, the built-in relay must tighten and close the contacts 11 - 14. The green LED lights up. Set limit values and delay time as required.

## 10 Error search

Relay does not turn on. Check whether:

- the supply voltage is correctly applied and coincides with the device voltage of the side type plate.
- One or two phases lie outside the set voltage range.
- The phase sequence is correct – if not, then change.
- The frequency of the monitored voltage is 50Hz or 60Hz.
- Interference caused by harmonics (e.g. by frequency converters) on the grid.

Relay does not turn off. Check whether:

- Feedback by connected motor is possible – if so, then adjust the device more sensitively.

In case of other errors, replace the device and send it in with the error description.

## 11 Technical data

<b>Control voltage Us</b>	<b>A1, A2</b>	
See information on the device	P222225	AC 230 V
	P222226	AC 400V
Tolerance Us	0.8Us ... 1.2Us	
Frequency fn	50 / 60Hz	
Tolerance fn	47Hz...63Hz	
Power consumption	<3VA	
Duty cycle	100%	
<b>Measurement inputs</b>	<b>L1, L2, L3</b>	
Measuring voltage UM	L – L max. 500Vac f = 40...70Hz	
Overvoltage – Undervoltage	< U >	
Switching point adjustable	± 2...20% UM	
Hysteresis	approx. 1%	
Asymmetry	Asy	
Switching point adjustable	± 5...15% UM	
Hysteresis	approx. 5%	
Shutdown delay time adjustable	0.1...12s	
Phase failure		
Switching point fixed	50% UM	
Hysteresis	approx. 5%	
Shutdown delay time fixed	0.1s	
<b>Relay output</b>	<b>11, 12, 14</b>	
Contacts	1 x Change-over contact	
Switching voltage	max. AC 415V	
Switching current	max. 6A	
Switching power (resistive load)	max. 1200VA	
max. 120W at DC 24V		
Nominal operating current Ie for changers	AC 15	
DC 13	Ie = 2 A	
Recommended back-up fuse	4A ( gG)	
Mechanical contact life	3x10 <sup>7</sup> switching cycles	
Electrical contact life	1x10 <sup>5</sup> switching cycles at 240V / 6A	
Switch-on delay	T1 <0.5s	

<b>Electrical safety - insulation</b>	<b>EN 60255-27</b>
Reinforced insulation of the relay contacts against control and measuring voltage	
Rated voltage	300V
Rated impulse withstand voltage	4000V
Overvoltage category	III
Degree of contamination	2
Transformer	EN 61558-2-6 (VDE 0551)
Overcurrent protection device on the installation side	<10A

#### Installation conditions

Installation position	No restrictions, any
Installation height	<2000m above sea level
Ambient temperature	-20°C...+55°C
Storage temperature	-25°C...+70°C
Climate class	3K3, IEC 60721-3-3
40°C 50% RH	
Vibration resistance EN 60068-2-6	2...13.2Hz ±1mm
13.2...100Hz 1g	
Shock resistance EN 60068-2-27	10g 11ms
EMC – Immunity Industry	EN 61000-6-2
EMC – Interference emission Industry	EN 61000-6-4

#### Housing Design K

#### Control cabinet installation

Dimensions (HxWxD)	75x22.5x115mm
Material	Plastic PA66, UL 94 V-2
Fastening	Mounting rail 35mm (IEC/EN 60715)
Option: Screw fastening	M4, only with additional latch (not included)
Degree of protection (EN60529) Housing / Terminals	IP 40 / IP 20
Connection cross-section – solid-core fine wire with ferrules	1x0.5...2.5mm <sup>2</sup> AWG 20...14 each 1x0.14mm <sup>2</sup> to 1.5mm <sup>2</sup> AWG 20...16 each
Stripping length	6.5mm
Screw terminal	M3
Standard Screwdriver	0.4x2.5x75mm
Tightening torque	0.5Nm (3.6lb.in)
Weight	approx. 160g

#### Subject to technical changes

## 12 Housing Type K

Dimensions in mm

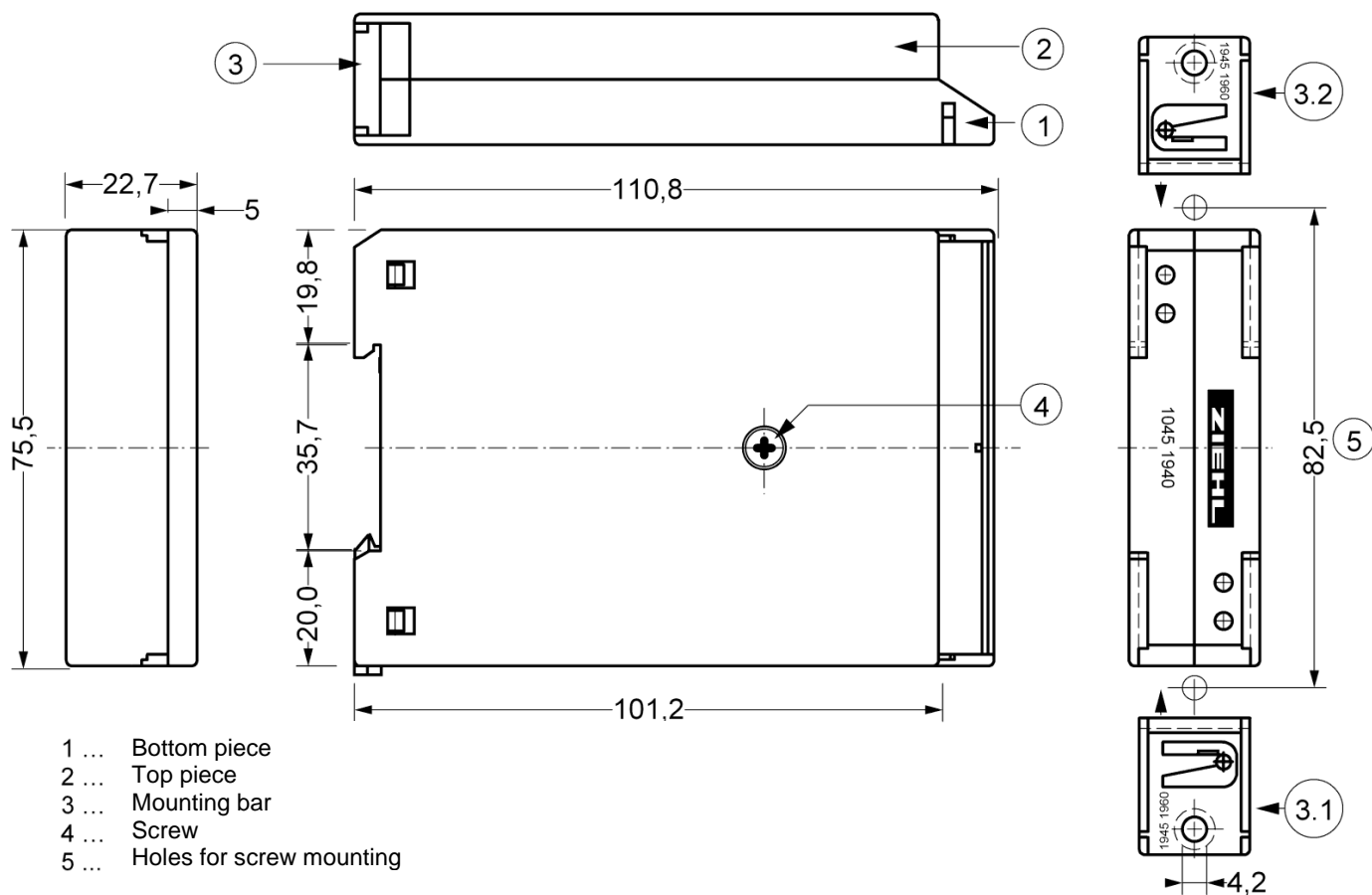

- 1 ... Bottom piece
- 2 ... Top piece
- 3 ... Mounting bar
- 4 ... Screw
- 5 ... Holes for screw mounting

## 13 Disposal



Disposal should be carried out properly and in an environmentally friendly manner in accordance with legal provisions.  
ZIEHL is registered with the EAR Foundation under WEEE no.: DE 49 698 543.