

Switch Mode Power Supply

S8VK-X (60/120/240/480-W Models)

**EtherNet/IP, Modbus
TCP-Compatible**
**Maximizing System Availability
Through the Connecting of
Equipment to IoT**



- Product replacement time, output voltage, output current, and more are acquired on the network and can be managed all at once
- Product status can be checked on-site using the indication monitor
- Operation possible at ambient temperatures from -40 to 70°C
- Power Boost function at 150% (240 and 480 W)
- Side-by-side mounting possible (up to 55°C)
- UL Class 2 conformance (90 W or less)
- Complies with EN/IEC 61558-2-16
- Coated PCBs for better resistance to environment



Refer to *Safety Precautions* on page 21.

Related Products

Noise filter
S8V-NF



Note: Refer to the S8V-NF Datasheet (Cat. No. T212) for details.

DC Electronic Circuit Protector
S8V-CP



Note: Refer to the S8V-CP Datasheet (Cat. No. T226-E1) for details.

Model Number Structure

Model Number Legend

Note: Not all combinations are possible. Refer to *List of Models* in *Ordering Information*, below.

S8VK- X **-EIP**
 1 2 3

1. Power Ratings

- 030: 30 W
- 060: 60 W
- 090: 90 W
- 120: 120 W
- 240: 240 W
- 480: 480 W

2. Output voltage (DC)

- 05: 5 V
- 12: 12 V
- 24: 24 V

3. Indication monitor

- A: With indication monitor
- None: Without indication monitor

S8VK-X

Ordering Information

Note: For details on normal stock models, contact your nearest OMRON representative.

With Indication Monitor

Power rating	Rated input voltage	Rated output voltage (DC)	Rated output current	Maximum boost current	Model number
90 W	100 to 240 VAC (allowable range: 85 to 264 VAC, 90 to 350 VDC)	24 V	3.75 A	---	S8VK-X09024A-EIP
120 W		24 V	5 A	6 A	S8VK-X12024A-EIP
240 W		24 V	10 A	15 A	S8VK-X24024A-EIP
480 W		24 V	20 A	30 A	S8VK-X48024A-EIP

Without Indication Monitor

Power rating	Rated input voltage	Rated output voltage (DC)	Rated output current	Maximum boost current	Model number
30 W	100 to 240 VAC (allowable range: 85 to 264 VAC, 90 to 350 VDC)	5 V	5 A *1	6 A	S8VK-X03005-EIP
60 W		12 V	4.5 A *2	5.4 A	S8VK-X06012-EIP
		24 V	2.5 A	3 A	S8VK-X06024-EIP
90 W		24 V	3.75 A	---	S8VK-X09024-EIP
120 W		24 V	5 A	6 A	S8VK-X12024-EIP
240 W		24 V	10 A	15 A	S8VK-X24024-EIP
480 W		24 V	20 A	30 A	S8VK-X48024-EIP

*1. Output power is 25 W at rated output current.

*2. Output power is 54 W at rated output current.

Mounting Brackets (Order Separately)

Name	Model number
Front-mounting bracket (For 30 W and 60 W models)	S82Y-VS10F
Side-mounting bracket (For 30 W and 60 W models)	S82Y-VS10S
Front-mounting bracket (For 240 W and 480 W models)	S82Y-VK10F

DIN Rail Mounting (Order Separately)

Part name	Model number
Mounting Rail (Material: Aluminum)	PPF-100N
	PPF-50N
	PPF-100N2
End Plate	PPF-M

EtherNet/IP communication cable recommended parts (Order Separately)

Please use a Category 5 or higher STP cable (shielded twisted pair cable).

Cable with Connectors

Item	Recommended manufacturer	Cable length (m)	Model
Wire Gauge and Number of Pairs: AWG26, 4-pair Cable Cable Sheath material: LSZH *2	OMRON	0.3	XS6W-6LSZH8SS30CM-Y
		0.5	XS6W-6LSZH8SS50CM-Y
		1	XS6W-6LSZH8SS100CM-Y
		2	XS6W-6LSZH8SS200CM-Y
		3	XS6W-6LSZH8SS300CM-Y
		5	XS6W-6LSZH8SS500CM-Y
Wire Gauge and Number of Pairs: AWG22, 2-pair Cable	OMRON	0.3	XS5W-T421-AMD-K
		0.5	XS5W-T421-BMD-K
		1	XS5W-T421-CMD-K
		2	XS5W-T421-DMD-K
		5	XS5W-T421-GMD-K
		10	XS5W-T421-JMD-K

*1. Cables with standard RJ45 plugs are available in the following lengths: 0.2 m, 0.3 m, 0.5 m, 1 m, 1.5 m, 2 m, 3 m, 5 m, 7.5 m, 10 m, 15 m, 20 m.

Cables with rugged RJ45 plugs are available in the following lengths: 0.3 m, 0.5 m, 1 m, 2 m, 3 m, 5 m, 10 m, 15 m.

For details, refer to the *Industrial Ethernet Connectors Catalog* (Cat. No. G019).

*2. The lineup features Low Smoke Zero Halogen cables for in-cabinet use and PUR cables for out-of-cabinet use.

*3. Cable colors are available in yellow, green, and blue. The last character of the model changes to "-G" or "-B".

Cable/Connector

Part name	Manufacturer	Model
Cable	Kuramo Electric Co.	KETH-SB *
RJ45 connector	Panduit Corporation	MPS588-C *

* It is recommended to use the cable and connector in combination described above.

Recommended Industrial Switching Hubs (Order Separately)

Name	Shape	Functions	Number of ports	Model
Industrial Switching Hubs		Quality of Service (QoS): EtherNet/IP control data priority 10/100BASE-TX, Auto-Negotiation	5	W4S1-05D

Ratings, Characteristics, and Functions

Item	Power rating		30 W		60 W		
	Rated output voltage (DC)		5 V		24 V		
	Indication monitor		None		None		
Efficiency *	115 VAC input		78% typ.		85% typ.		
	230 VAC input		77% typ.		86% typ.		
Input conditions	Voltage range *		Single-phase, 85 to 264 VAC, 90 to 350 VDC, 265 to 300 VAC (1 second)				
	Frequency *		50/60 Hz (47 to 450 Hz)				
	Input current *	115 VAC input		0.53 A typ.		0.99 A typ.	
		230 VAC input		0.32 A typ.		0.61 A typ.	
	Power factor *		---				
	Leakage current *	115 VAC input		0.5 mA max.			
		230 VAC input		1 mA max.			
	Inrush current *	115 VAC input		16 A typ.			
230 VAC input		32 A typ.					
Output characteristics	Rated output current		5 A		4.5 A		
	Rated output power		25 W		54 W		
	Maximum boost current		6 A		5.4 A		
	Voltage adjustment range *		4.5 to 5.8V (with V. ADJ)		10.8 to 14 V (with V. ADJ)		
	Ripple noise voltage *	100 to 240 VAC input		130 mVp-p max. at 20 MHz of bandwidth		120 mVp-p max. at 20 MHz of bandwidth	
						110 mVp-p max. at 20 MHz of bandwidth	
	Input variation influence *		0.5% max.				
	Load variation influence *		1.5% max.				
	Temperature variation influence	100 to 240 VAC input		0.05%/°C max.			
	Start up time *	115 VAC input		1000 ms max.		1000 ms max.	
		230 VAC input		1000 ms max.		1000 ms max.	
Hold time *	115 VAC input		45 ms typ.		20 ms typ.		
	230 VAC input		240 ms typ.		120 ms typ.		
Additional functions	Overload protection		Yes, automatic reset, intermittent operation type, Refer to <i>Overload Protection</i> on page 9 for details.				
	Overvoltage protection		Yes, 130% or higher of rated output voltage, power shut off (shut off the input voltage and turn on the input again), Refer to <i>Overvoltage Protection</i> on page 9 for details.				
	Series operation		Yes (For up to two Power Supplies; external diodes required.)				
	Parallel operation		Yes (For up to two Power Supplies), Refer to <i>Parallel Operation</i> on page 23 for details.				
	Output indicator		Yes (LED: Green)				
	Alarm indicator		Yes (LED: Red)				
	Indication monitor	Measurement and display details		Refer to <i>Communication and Indication Items</i> on page 8 for details.			
		Main display		None			
	Ethernet communication	Measurement and display details		Refer to <i>Communication and Indication Items</i> on page 8 for details.			
		Communication protocol		EtherNet/IP, Modbus TCP			
Physical layer		100BASE-TX					
Communication specifications		Refer to <i>Communication Specifications</i> on page 9 for details.					
Insulation	Withstand voltage		3.0 kVAC for 1 min. (between all input terminals and output terminals, all EtherNet/IP ports), current cutoff 20 mA				
			2.0 kVAC for 1 min. (between all input terminals and PE terminals), current cutoff 20 mA				
			1.0 kVAC for 1 min. (between all output terminals and PE terminals), current cutoff 30 mA				
			0.5 kVAC for 1 min. (between all output terminals and all EtherNet/IP ports), current cutoff 30 mA				
	Insulation resistance		100 MΩ min. (between all output terminals and all input terminals/PE terminals) at 500 VDC				
100 MΩ min. (between all EtherNet/IP ports and all input terminals) at 500 VDC							
Environment	Ambient operating temperature *		-40 to 70°C (Derating is required according to the temperature. Refer to <i>Engineering Data</i>) (with no condensation or icing)				
	Storage temperature		-40 to 85°C (with no condensation or icing)				
	Ambient operating humidity		95% max. (Storage humidity: 95% max.)				
	Vibration resistance		10 to 55 Hz, maximum 5 G, 0.42 mm half amplitude for 2 h each in X, Y, and Z directions				
	Shock resistance		150 m/s ² , 3 times each in ±X, ±Y, ±Z directions				
Reliability	MTBF *		160,000 hrs typ.				
	Life expectancy *		10 years min.				
Construction	Weight		250 g max.		250 g max.		
	Cooling fan		No				
	Degree of protection		IP20 by EN/IEC 60529				

* Refer to *Definitions of the Terms Under Ratings, Characteristics, and Functions* on page 7.

Item	Power rating		90 W		120 W		
	Rated output voltage (DC)		24 V		24 V		
	Indication monitor		Included	None	Included	None	
Efficiency *	115 VAC input		86% typ.	87% typ.	90% typ.	90% typ.	
	230 VAC input		87% typ.	88% typ.	92% typ.	92% typ.	
Input conditions	Voltage range *		Single-phase, 85 to 264 VAC, 90 to 350 VDC, 265 to 300 VAC (1 second)				
	Frequency *		50/60 Hz (47 to 450 Hz)		50/60 Hz (47 to 63 Hz)		
	Input current *	115 VAC input		1.7 A typ.	1.7 A typ.	1.2 A typ.	1.2 A typ.
		230 VAC input		1.0 A typ.	1.0 A typ.	0.63 A typ.	0.63 A typ.
	Power factor *		---		0.9 min.		
	Leakage current *	115 VAC input		0.5 mA max.			
230 VAC input			1 mA max.				
Inrush current *	115 VAC input		16 A typ.				
	230 VAC input		32 A typ.				
Output characteristics	Rated output current		3.75 A		5 A		
	Rated output power		90 W		120 W		
	Maximum boost current		---		6 A		
	Voltage adjustment range *		23.0 to 24.1 V		21.6 to 28 V (with V. ADJ)		
	Ripple noise voltage * 100 to 240 VAC input		300 mVp-p max. at 20 MHz of bandwidth		150 mVp-p max. at 20 MHz of bandwidth		
	Input variation influence *		0.5% max.				
	Load variation influence *		1.5% max.				
	Temperature variation influence	100 to 240 VAC input		0.05%/°C max.			
		Start up time *	115 VAC input	1000 ms max.		1000 ms max.	
	230 VAC input		1000 ms max.		1000 ms max.		
Hold time *	115 VAC input	25 ms typ.		35 ms typ.			
	230 VAC input	130 ms typ.		35 ms typ.			
Additional functions	Overload protection		Yes, automatic reset, intermittent operation type, Refer to <i>Overload Protection</i> on page 9 for details.				
	Overvoltage protection		Yes, 110% or higher of rated output voltage (90 W), 130% or higher of rated output voltage (120 W), power shut off (shut off the input voltage and turn on the input again, Refer to <i>Overvoltage Protection</i> on page 9 for details.				
	Series operation		Yes (For up to two Power Supplies, external diodes are required.)				
	Parallel operation		Yes (For up to two Power Supplies), Refer to <i>Parallel Operation</i> on page 23 for details.				
	Output indicator		Yes (LED: Green)				
	Alarm indicator		Yes (LED: Red)				
	Indication monitor	Measurement and display details		Refer to <i>Communication and Indication Items</i> on page 8 for details.			
		Main display		7-segment LED (White)	None	7-segment LED (White)	None
Ethernet communication	Measurement and display details		Refer to <i>Communication and Indication Items</i> on page 8 for details.				
	Communication protocol		Ethernet/IP, Modbus TCP				
	Physical layer		100BASE-TX				
Communication specifications		Refer to <i>Communication Specifications</i> on page 9 for details.					
Insulation	Withstand voltage		3.0 kVAC for 1 min. (between all input terminals and output terminals, all EtherNet/IP ports), current cutoff 20 mA				
			2.0 kVAC for 1 min. (between all input terminals and PE terminals), current cutoff 20 mA				
			1.0 kVAC for 1 min. (between all output terminals and PE terminals), current cutoff 30 mA				
			0.5 kVAC for 1 min. (between all output terminals and all EtherNet/IP ports), current cutoff 30 mA				
Insulation resistance		100 MΩ min. (between all output terminals and all input terminals/PE terminals) at 500 VDC					
		100 MΩ min. (between all EtherNet/IP ports and all input terminals) at 500 VDC					
Environment	Ambient operating temperature *		-40 to 70°C (Derating is required according to the temperature. Refer to <i>Engineering Data</i>) (with no condensation or icing)				
	Storage temperature		-40 to 85°C (with no condensation or icing)				
	Ambient operating humidity		95% max. (Storage humidity: 95% max.)				
	Vibration resistance		10 to 55 Hz, maximum 5 G, 0.42 mm half amplitude for 2 h each in X, Y, and Z directions				
	Shock resistance		150 m/s ² , 3 times each in ±X, ±Y, ±Z directions				
Reliability	MTBF *		110,000 hrs typ.	150,000 hrs typ.	110,000 hrs typ.	140,000 hrs typ.	
	Life expectancy *		10 years min.				
Construction	Weight		350 g max.		400 g max.		
	Cooling fan		No				
	Degree of protection		IP20 by EN/IEC 60529				

* Refer to *Definitions of the Terms Under Ratings, Characteristics, and Functions* on page 7.

Item	Power rating		240 W		480 W		
	Rated output voltage (DC)		24 V		24 V		
	Indication monitor		Included	None	Included	None	
Efficiency *	115 VAC input		91% typ.	91% typ.	92% typ.	92% typ.	
	230 VAC input		93% typ.	93% typ.	94% typ.	94% typ.	
Input conditions	Voltage range *		Single-phase, 85 to 264 VAC, 90 to 350 VDC, 265 to 300 VAC (1 second)				
	Frequency *		50/60 Hz (47 to 63 Hz)		50/60 Hz (47 to 63 Hz)		
	Input current *	115 VAC input		2.4 A typ.	2.4 A typ.	4.6 A typ.	4.6 A typ.
		230 VAC input		1.2 A typ.	1.2 A typ.	2.3 A typ.	2.3 A typ.
	Power factor *		0.9 min.				
	Leakage current *	115 VAC input		0.5 mA max.			
230 VAC input			1 mA max.				
Inrush current *	115 VAC input		16 A typ.				
	230 VAC input		32 A typ.				
Output characteristics	Rated output current		10 A		20 A		
	Rated output power		240 W		480 W		
	Maximum boost current		15 A		30 A		
	Voltage adjustment range *		21.6 to 28 V (with V. ADJ)				
	Ripple noise voltage *	100 to 240 VAC input	140 mVp-p max. at 20 MHz of bandwidth		130 mVp-p max. at 20 MHz of bandwidth		
	Input variation influence *		0.5% max.				
	Load variation influence *		1.5% max.				
	Temperature variation influence	100 to 240 VAC input	0.05%/°C max.				
	Start up time *	115 VAC input		1000 ms max.		1000 ms max.	
		230 VAC input		1000 ms max.		1000 ms max.	
Hold time *	115 VAC input		35 ms typ.		25 ms typ.		
	230 VAC input		35 ms typ.		25 ms typ.		
Additional functions	Overload protection		Yes, automatic reset, intermittent operation type, Refer to <i>Overload Protection</i> on page 9 for details.				
	Overvoltage protection		Yes, 130% or higher of rated output voltage, power shut off (shut off the input voltage and turn on the input again), Refer to <i>Overvoltage Protection</i> on page 9 for details.				
	Series operation		Yes (For up to two Power Supplies; external diodes required.)				
	Parallel operation		Yes (For up to two Power Supplies), Refer to <i>Parallel Operation</i> on page 23 for details.				
	Output indicator		Yes (LED: Green)				
	Alarm indicator		Yes (LED: Red)				
	Indication monitor	Measurement and display details		Refer to <i>Communication and Indication Items</i> on page 8 for details.			
		Main display		7-segment LED (White)	None	7-segment LED (White)	None
	Ethernet communication	Measurement and display details		Refer to <i>Communication and Indication Items</i> on page 8 for details.			
		Communication protocol		EtherNet/IP, Modbus TCP			
Physical layer		100BASE-TX					
Communication specifications		Refer to <i>Communication Specifications</i> on page 9 for details.					
Insulation	Withstand voltage		3.0 kVAC for 1 min. (between all input terminals and output terminals, all EtherNet/IP ports), current cutoff 20 mA				
	Insulation resistance		2.0 kVAC for 1 min. (between all input terminals and PE terminals), current cutoff 20 mA				
Environment	Ambient operating temperature *		-40 to 70°C (Derating is required according to the temperature. Refer to <i>Engineering Data</i>) (with no condensation or icing)				
	Storage temperature		-40 to 85°C (with no condensation or icing)				
	Ambient operating humidity		95% max. (Storage humidity: 95% max.)				
	Vibration resistance		10 to 55 Hz, maximum 5 G, 0.42 mm half amplitude for 2 h each in X, Y, and Z directions				
	Shock resistance		150 m/s ² , 3 times each in ±X, ±Y, ±Z directions				
Reliability	MTBF *		100,000 hrs typ.	130,000 hrs typ.	90,000 hrs typ.	120,000 hrs typ.	
	Life expectancy *		10 years min.				
Construction	Weight		700 g max.		1,100 g max.		
	Cooling fan		No				
	Degree of protection		IP20 by EN/IEC 60529				

* Refer to *Definitions of the Terms Under Ratings, Characteristics, and Functions* on page 7.

Standards

Standards	Harmonic current emissions		Conforms to EN 61000-3-2
	EMI	Conducted emissions	Conforms to EN 61204-3 Class B, EN 55011 Class B
		Radiated emissions	Conforms to EN 61204-3 Class B, EN 55011 Class B
	EMS		Conforms to EN 61204-3 high severity levels
	Safety standards		UL 508 (For 30 W, 60 W, and 90 W only Class 2 Output: Per UL 1310) CSA C22.2 No. 107.1 (For 30 W, 60 W, and 90 W only Class 2 Output: Per CSA C22.2 No. 223) UL 62368-1 (Recognition) OVC II (≤ 3000 m) Pol2 (For 30 W, 60 W, and 90 W only LPS) CSA C22.2 No. 62368-1 (cUR) OVC II (≤ 3000 m) Pol2 (For 30 W, 60 W, and 90 W only LPS) EN 62477-1 OVC III (≤ 2000 m) OVC II (2000 m < and ≤ 3000 m) Pol2 EN 62368-1 OVC II (≤ 3000 m) Pol2 (For 30 W, 60 W, and 90 W only LPS) RCM (EN61000-6-4) Korea Radio Waves Act (Law No. 10564) Conforms to PELV (EN/IEC 60204-1) Conforms to EN/IEC 61558-2-16 BIS: IS 13252 (Part1) (240 W and 480 W only)
SEMI		Conforms to F47-0706 (200 to 240 VAC input)	

- EMI (radiated emissions) conform to Class B when this Power Supply is installed in a control panel.
- EN/IEC 61558-2-16
 The S8VK-X was designed based on EN/IEC 61558-2-16.
 Currently, IEC 61558-2-17 has been replaced by IEC 61558-2-16.
 When certification was received for EN/IEC 60204-1 (Machinery Safety), it was necessary to go through a control transformer to the control circuits. However, a control transformer is not always necessary for product that have been certified for the safety standard for OVCIII or for product that use a transformer that conforms to EN/IEC 61558-2-16.
- Safety Standards for a DC Input
 When DC is used, UL 62368-1, cUR (CSA C22.2 No. 62368-1), EN/IEC 62368-1, EN 62477-1 and EN/IEC 61558-2-16 are applicable to safety standards.
 Safety standard compliance is achievable by connecting a UL-certified fuse as specified below.
 Select an external fuse that satisfies the following conditions:
 S8VK-X03005-EIP, S8VK-X06012-EIP, S8VK-X06024-EIP (350 VDC or more, 6 A)
 S8VK-X09024□-EIP, S8VK-X12024□-EIP, S8VK-X24024□-EIP (350 VDC or more, 8 A)
 S8VK-X48024□-EIP (350 VDC or more, 12 A)
- To comply with PELV output requirements for EN/IEC 60204-1, ground the negative side of the output (-V) to a protective earth (PE).
- The BIS Standard is an Indian standard that has been in effect for this product since April 2021, and certification has been acquired for below-mentioned models to enable individual product export to India.
 S8VK-X24024-EIP
 S8VK-X24024A-EIP
 S8VK-X48024-EIP
 S8VK-X48024A-EIP

Definitions of the Terms Under Ratings, Characteristics, and Functions

Input conditions	Efficiency	The value is when both rated output voltage and rated output current are satisfied.
	Voltage range	Do not use an inverter output for the product. Inverters with an output frequency of 50/60 Hz are available, but the rise in the internal temperature of the product may result in smoking or burning. If the input is connected to a UPS, do not connect a UPS with a square-wave output. Doing so will cause the internal temperature of the product to increase, possibly causing smoking or burning.
	Frequency	
	Input current	The value is when both rated output voltage and rated output current are satisfied.
	Power factor	The value is when both rated output voltage and rated output current are satisfied.
	Leakage current	The value is determined according to the Electrical Appliances and Material Safety Act.
	Inrush current	Values for a cold start at 25°C. Refer to <i>Inrush Current, Startup Time, and Output Hold Time</i> on page 8 for details.
Output characteristics	Voltage adjustment range	If the output voltage adjuster (V. ADJ) is turned, the voltage will increase by more than of the voltage adjustment range. When adjusting the output voltage, confirm the actual output voltage from the product and be sure that the load is not damaged.
	Ripple noise voltage	The value is when both rated output voltage and rated output current are satisfied. A characteristic when the ambient operating temperature is 25°C.
	Static input variation influence	This is the maximum variation in the output voltage when the input voltage is gradually changed within the allowable input voltage range at the rated output voltage and rated output current.
	Load variation influence	100 to 240 VAC input, in the range of 0 A to the rated output current.
	Startup time	The value is when both rated output voltage and rated output current are satisfied and at room temperature (25°C). Refer to <i>Inrush Current, Startup Time, and Output Hold Time</i> on page 8 for details.
	Hold time	The value is when both rated output voltage and rated output current are satisfied and at room temperature (25°C). Refer to <i>Inrush Current, Startup Time, and Output Hold Time</i> on page 8 for details.
Environment	Ambient operating temperature	At -40 to -25°C, time will be required before the rated output voltage is output after the input voltage is input. Also, the ripple noise value may exceed the value shown in the above table.
Reliability	MTBF	MTBF is calculated according to JEITA RCR-9102. MTBF stands for Mean Time Between Failures, which is calculated according to the probability of accidental device failures, and indicates reliability of devices. Therefore, it does not necessarily represent a life of the product.
	Life expectancy	Refer to <i>Recommended Replacement Periods and Periodic Replacement for Preventive Maintenance</i> on page 28 for details.

Communication and Indication Items

Item	Communication *	Indication monitor *	Resolution		Data update cycle	Details
Output voltage measurement	Yes	Yes	0.1 V		5 ms	Measurement accuracy ±2% (percentage of output voltage value) ±1 digit
Output current measurement	Yes	Yes	0.1 A		5 ms	Measurement accuracy ±5% (percentage of rated output current) ±1 digit
Peak hold current measurement	Yes	Yes	0.1 A		5 ms	Measurement accuracy ±5% (percentage of rated output current) ±1 digit
Years until replacement	Yes	Yes	0.1 years		1 min	Range 0.0 to 15.0 years (communication) FUL (Full) / HLF (Half) / 0.0 to 4.9 years (indication monitor)
Percentage until replacement	Yes	Yes	0.1%		1 min	Range 0.0 to 100%
Total run time	Yes	Yes	Communication	1 h	1 min	Range 0 to 262,800 h (communication) 0 to 263 kh (indication monitor)
			Indication monitor	1 kh		
Continuous run time	Yes	None	1 min		1 min	Range 0 to 15,768,000 min
Self-diagnostics	Yes	Yes	None		None	Refer to <i>Self-Diagnostics Function</i> on page 12 for details.
Product model	Yes	None	None		None	Product model is expressed in ASCII code
Serial number	Yes	None	None		None	Expressed in hexadecimal (4-byte)
Firmware version	Yes	None	None		None	Expressed in hexadecimal (2-byte)
MAC address	Yes	None	None		None	None
IP address	Yes	None	None		None	None
IP address setting method	Yes	None	None		None	Static IP address/BOOTP selection

Note: For details on the communication function and setting method, refer to the *Switch Mode Power Supply S8VK-X Communication Manual* (Man. No. T213).

* Communication cycle can be set from 100 to 10,000 ms. The indication update cycle is 50 ms.

Inrush Current, Startup Time, and Output Hold Time

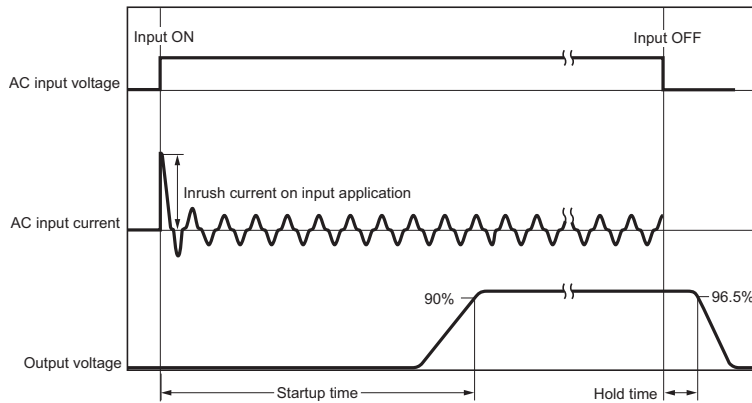

Note: Twice the normal inrush current will flow during parallel operation or for backup operation. Also, if crossover wiring is used for N number of Power Supplies, an inrush current of N times the inrush current for a standalone Power Supply will flow. Therefore, check the fusing characteristics of fuses and operating characteristics of breakers making sure that the external fuses will not burn out and the circuit breakers will not be activated by the inrush current.

Overload Protection

When the load current reaches 121% to 160% of the rated current for S8VK-X03005-EIP, S8VK-X06012-EIP, S8VK-X06024-EIP, and S8VK-X12024□-EIP, 101% to 110% for S8VK-X09024□-EIP, or 151% to 165% for S8VK-X24024□-EIP and S8VK-X48024□-EIP, output voltage is automatically lowered to protect the Power Supply from short-circuit currents and overcurrents.

When the output current falls within the rated range, the overload protection function is automatically cleared.

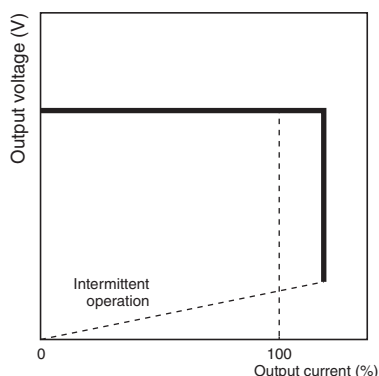

- Note:**
1. Internal parts may possibly deteriorate or be damaged if a short-circuited or overcurrent state continues during operation.
 2. Internal parts may possibly deteriorate or be damaged if the Power Supply is used for applications with frequent inrush current or overloading at the load end. Do not use the Power Supply for such applications.

Overvoltage Protection

Overvoltage will be detected to prevent the load from being subjected to excessive voltage when the feedback circuit in the Power Supply fails, etc. If an excessive voltage that is approximately 130% of the rated output voltage (but approximately 110% of the rated output voltage for only the S8VK-X09024□-EIP) or more is output, the output voltage is shut OFF.

Reset the input power by turning it OFF for at least three minutes and then turning it back ON again.

Note: Do not turn ON the power again until the cause of the overvoltage has been removed.

Communication Specifications

Item	Specification	
Media access method	CSMA/CD	
Modulation system	Baseband	
Topology	Star configuration	
Transmission speed	100 Mbps	
Transmission medium	Twisted pair cable (with shield: STP): Category 5, 5e or above	
Maximum transmission distance (distance between hub and node)	100 m	
Tag data Link	Class1	Connection resource: 1 max.
	Number of connected nodes	1
	Number of tag sets	1
	Packet interval (RPI)	100 to 10,000 ms
	Time-out value	Multiple of RPI
	Connection type	Point To Point Connection (fixed)
Explicit message	Class3	Number of clients that can communicate at one time: 2 max.
	UCMM	Number of clients that can communicate at one time: 2 max.
Modbus message	Modbus TCP	Number of clients that can communicate at one time: 2 max.
Factory default values	IP address	192.168.250.20
	Subnet mask	255.255.255.0
	Default gateway	0.0.0.0
	IP address setting method	Static IP address

Module Status and Network Status Indicators

Name	Color	Status	Operating status
Module status Indicator (MS)	Green	Lit	Normal
		Flashing	---
	Red	Lit	RAM abnormality, EEPROM abnormality
		Flashing	Voltage measurement abnormality, current measurement abnormality
	---	Not lit	No power supply
Green/Red	Flashing	When power is turned ON	
Network status Indicator (NS)	Green	Lit	Connection established
		Flashing	Connection not established
	Red	Lit	Multiple IP addresses
		Flashing	Connection timeout BOOTP server connection abnormality
	---	Not lit	No power supply
	Green/Red	Flashing	When power is turned ON

Communication Reset Function

This function temporarily resets the communication settings to their factory default values. Use this function when the IP address previously set is no longer known and communication is not possible.

Setting Method

- With the reset key pressed, turn on the power supply.
- Continue to hold the reset key for 10 seconds.
While pressed, an alarm indicator will flash in 0.5-second intervals.
(For models with an indication monitor, the main display and operation indicator will also repeatedly turn all indicators on and off in 0.5-second intervals.)

- After 10 seconds have elapsed, the system shifts into the communication reset state, and the communication setting values temporarily reset to their factory default values.
In the communication reset state, the alarm indicator will flash in 1-second intervals. (For models with an indication monitor, the main display and operation indicator will return to normal operation.)
- In the communication reset state, reset the communication settings from the host device.
- After setting, turn on the power supply once again, and confirm that the set values have been changed.

- Note:**
- After confirming that the product output indicator has turned off, turn on the power supply once again.
 - The only way to exit the communication reset state is to restart the power supply.
 - If you do not change the communication settings during step (4), settings will return to their prior values once the communication reset is ended.

Switching Indications

All indicators of the indication monitor will be lit for 1 second when power is turned on. After that, each status can be displayed using the Indication switching key.

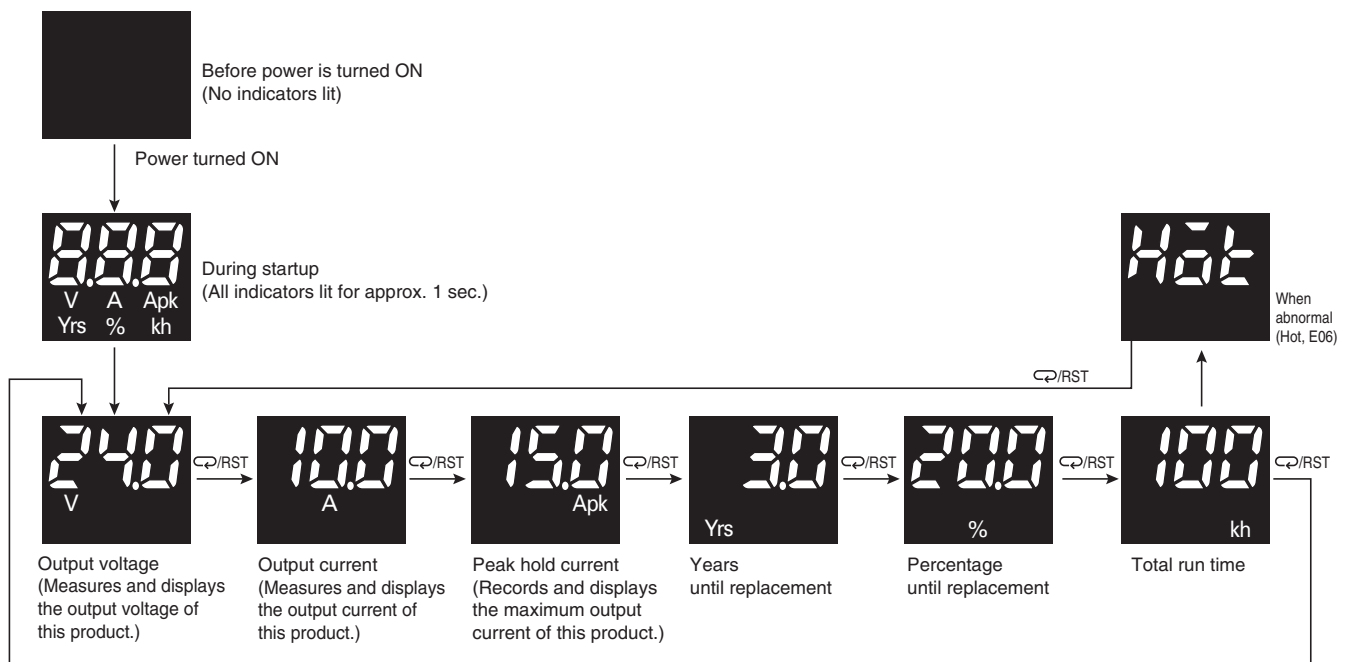

Note: For the factory setting, the output voltage will be displayed when the power supply is first turned ON. Thereafter, the status before shutting down will be displayed.

Peak Hold Current

The output current maximum value is stored as the peak hold current. (5 ms average value)
Measurement is not performed for approximately 3 seconds immediately after the input power is turned ON.

Peak Hold Current Reset

When the peak hold current is displayed, it can be reset by pressing the Reset key for 3 seconds or more.

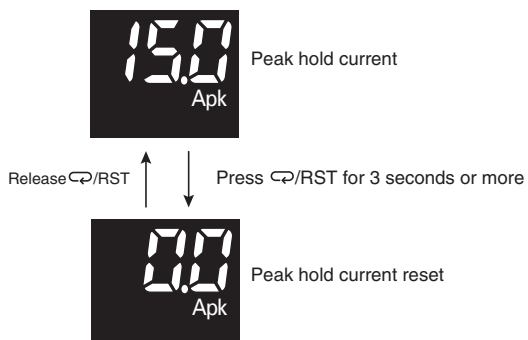

Note: For types without an indication monitor, it is not possible to reset the peak hold current via reset key operation.

Replacement Time Calculation Function

This Power Supply is equipped with electrolytic capacitors. The electrolyte inside the electrolytic capacitors penetrates the sealing rubber and evaporates as time passes after it is manufactured. This causes deterioration of characteristics, such as decreasing the capacitance. Due to this deterioration of the characteristics of the electrolytic capacitor, this Power Supply decreases its performance as time passes. The replacement time calculation function calculates an approximate period left for maintenance of this Power Supply due to deterioration of electrolytic capacitors. Use this function to know the approximate replacement time of the Power Supply.

Note: The replacement time calculation function indicates an approximate period left for maintenance, based on deterioration of the electrolytic capacitors. It does not predict failures resulting from other causes.

Principle of Operation

The deterioration speed of the electrolytic capacitors varies considerably with the ambient temperature. (Generally the speed follows the Arrhenius Law, i.e., for every 10°C increase in the temperature, the rate of degradation doubles.) The S8VK-X monitors the temperature inside the Power Supply, and calculates the amount of deterioration according to the running hours and internal temperature.

- Note:**
1. Due to degradation of internal electronic parts, replace the Power Supply approximately 15 years after purchase even if the replacement time calculation for years and percentage do not appear.
 2. The replacement time is accelerated or decelerated according to operating conditions. Periodically check indication.
 3. The accuracy of the replacement time calculation function will be reduced in applications where the input power turns ON and OFF frequently.

Years until replacement

(Indication monitor)
FULL is indicated at the time of purchase (when initially powered on), and continues to be indicated for approximately one month. Afterward, the state of deterioration for the electrolytic capacitor is calculated based on the usage environment, and *HLF* is indicated when deterioration progresses. When the years until replacement reaches 5 years or less, it is indicated in 0.1 step increments within the range of 4.9 to 0.0. (Depending on the usage environment, the number of years may be indicated after *FULL* without *HLF* being indicated.)

(Communication)
Communication is calculated in 0.1 step increments within a range of 15.0 to 0.0.

Note: The number of years until replacement may vary if there are frequent load variations or in locations where the ambient temperature fluctuates drastically.

Percentage until replacement

With the number of years until replacement at the time of manufacture set as 100%, as deterioration of the electrolytic capacitor progresses through use, it decreases in 0.1% step increments.

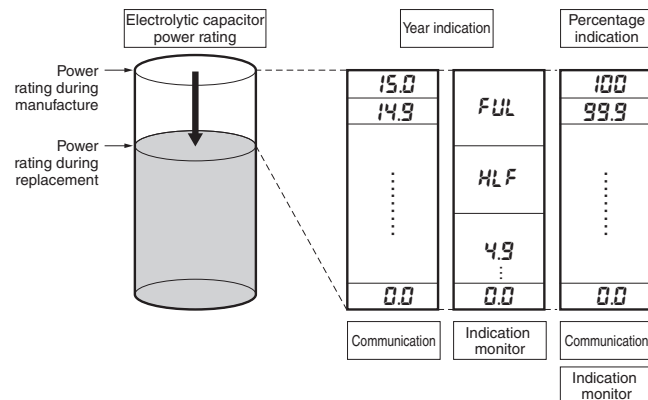

Relationship between electrolytic capacitor power rating and indicator

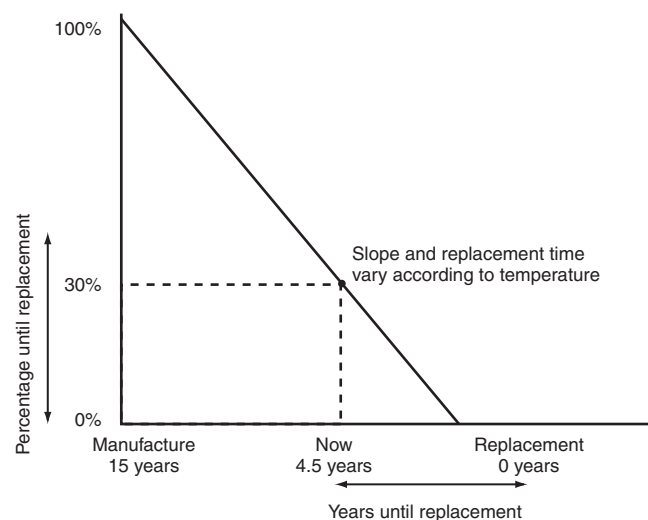

Relationship between number of years and percentage until replacement

Difference between Expected Life and Replacement Time

OMRON calculates the expected life based on the following conditions.

1. Rated input voltage
2. Load rate: 50%
3. Ambient temperature: +40°C
4. Standard mounting

Note: As the values were calculated using an aluminum electrolytic condenser temperature rise test, they are not guaranteed. Use this data as a reference for maintenance and replacement time calculation.

The expected life span of the S8VK-X is 10 years minimum. Also, a replacement time calculation function is included among the functions of the S8VK-X. The replacement time is the service life (the Power Supply's internal temperature is monitored at all times) of the internal electrolytic capacitor in actual operating conditions, and varies according to the customers operating conditions. 15 years is taken as the maximum period of the maintenance forecast.

Total Run Time

The accumulated value of the product's time powered on is measured as the total run time.

(With indication monitor)

Total run time increases in t (kh) steps with use.

(Communication)

Total run time increases in t (h) steps with use.

Time Chart

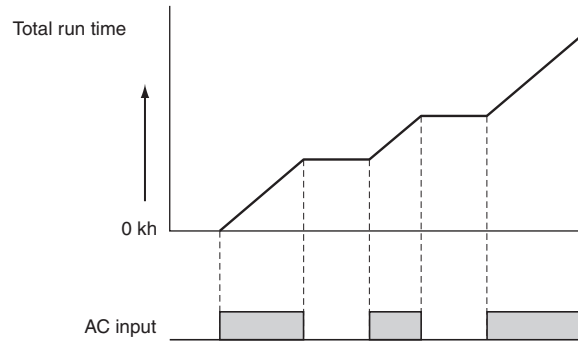

Note: 1. The total run time does not include the time that the Power Supply is OFF.

2. The total run time measures the total time that power is being supplied and is not related in any way to deterioration in the electrolytic capacitor built into the Power Supply or to the effects of the ambient temperature.

Continuous Run Time (Communication Only)

The product's time powered on is measured as continuous run time, and the continuous run time increases in 1 (min) steps with use.

Continuous run time will be reset when power is turned off.

Time Chart

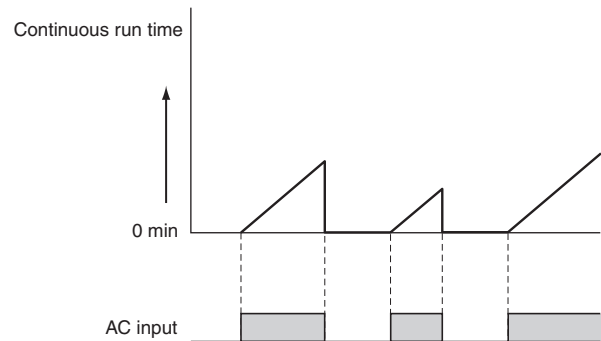

Note: 1. The continuous run time does not include the time that the Power Supply is OFF.

2. The continuous run time measures the total time that power is being supplied and is not related in any way to deterioration in the electrolytic capacitor built into the Power Supply or to the effects of the ambient temperature.

Self-Diagnostics Function

Main display	Alarm indicator	Status name	Details	Restoration method
- - -	Lit	Measurement abnormality	Output voltage, output current, etc., cannot be measured normally due to noise	Automatic reset.
H $\bar{0}$ t (Flashing)	Lit	Overheating alarm	Overheated status has continued for 1 to 180 minutes	Automatic reset.
E06 (Flashing)	Lit	Product overheat abnormality	Overheated status has continued for more than 180 minutes	Replace the Power Supply, as internal parts may be deteriorated.
E03	Lit	Memory error	If there is an internal memory error, damage to data, etc., may occur	Turn the AC input OFF then ON again. If the Product is not reset, contact the dealer.

Note: 1. External noise is probable as a cause of - - - and E03 errors.

2. When E03 is displayed, indication switching is not possible.

3. Operation out of the derating curve area, ventilation errors, and incorrect mounting direction are probable as a cause of H $\bar{0}$ t and E06 errors.

4. Pressing the indication switching key on the H $\bar{0}$ t and E06 display screen will return to the normal display screen.

5. When E06 is displayed, the years/percentage until replacement will become 00 and 00% respectively.

Connections

Block Diagrams

S8VK-X03005-EIP/06012-EIP/06024-EIP

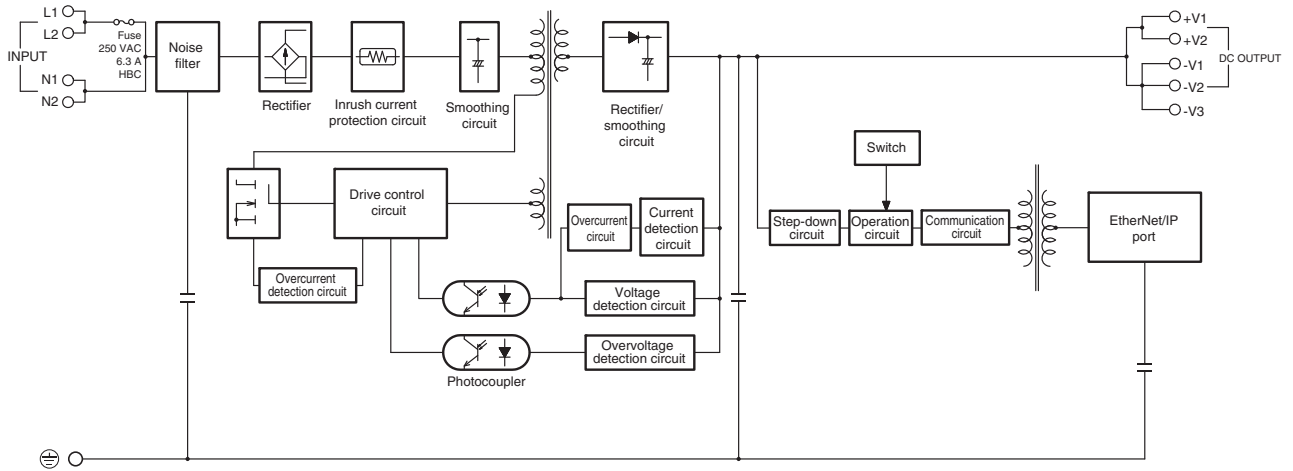

S8VK-X09024-EIP

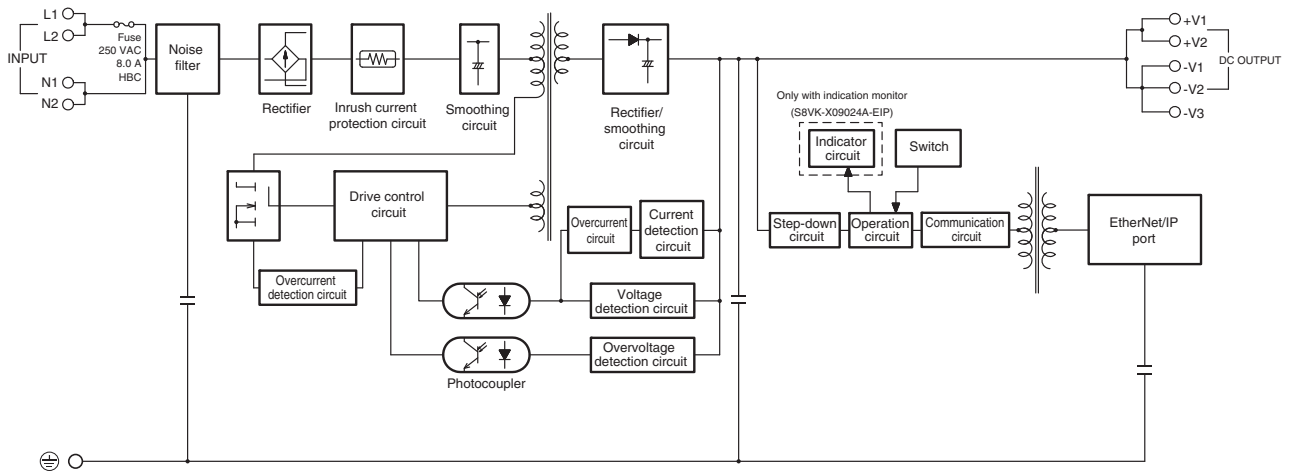

S8VK-X12024-EIP

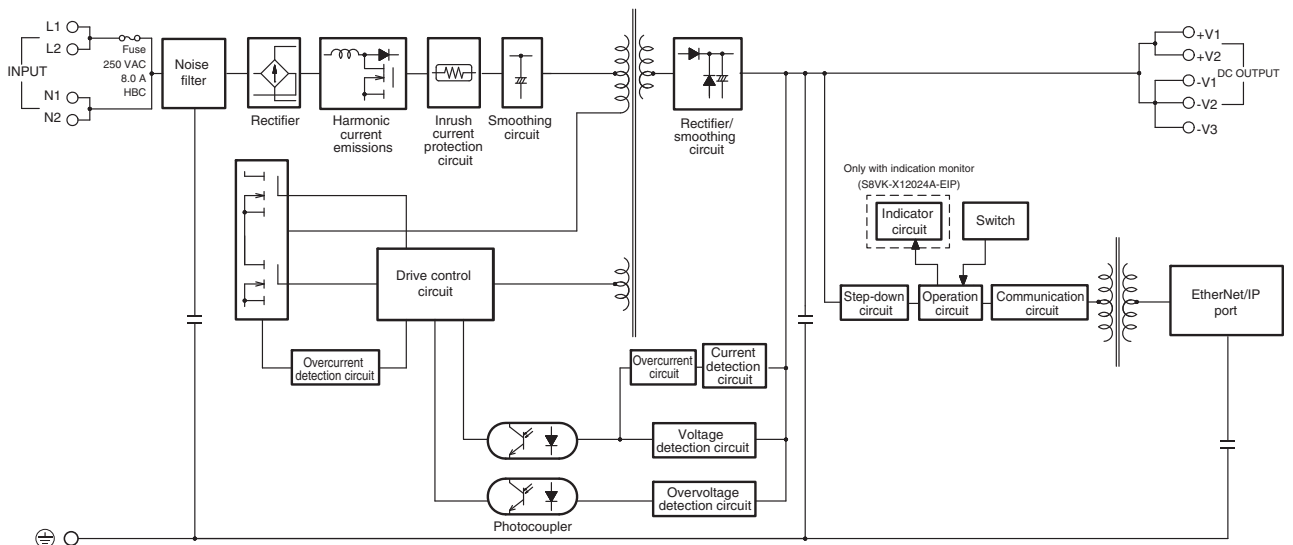

S8VK-X

S8VK-X24024-EIP

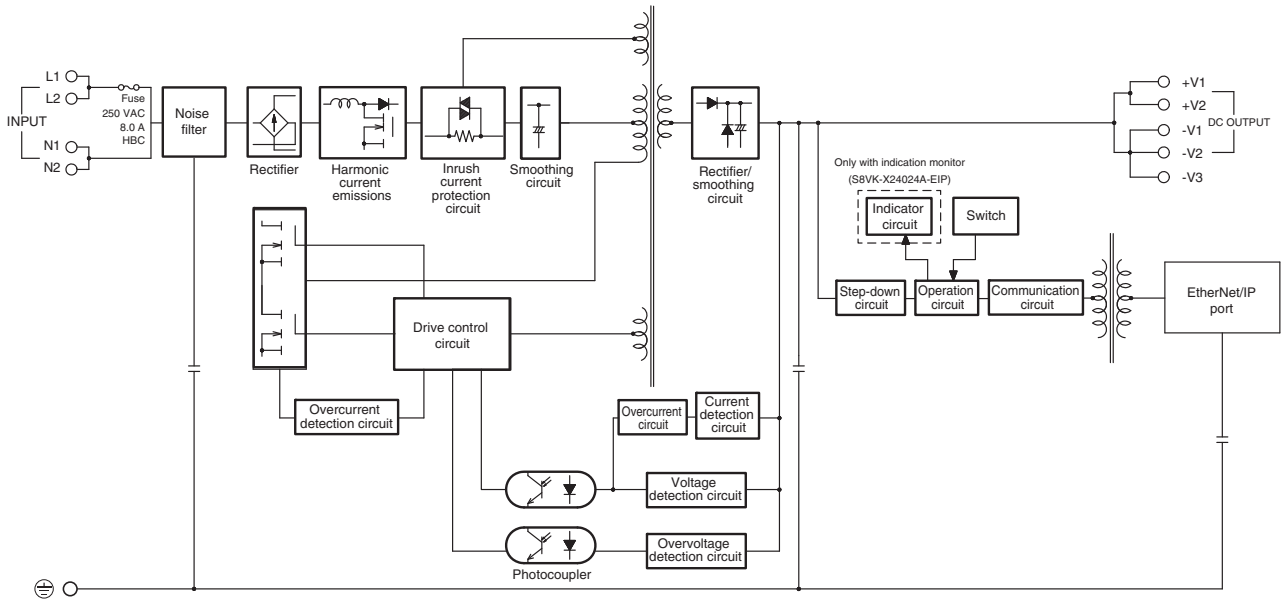

S8VK-X48024-EIP

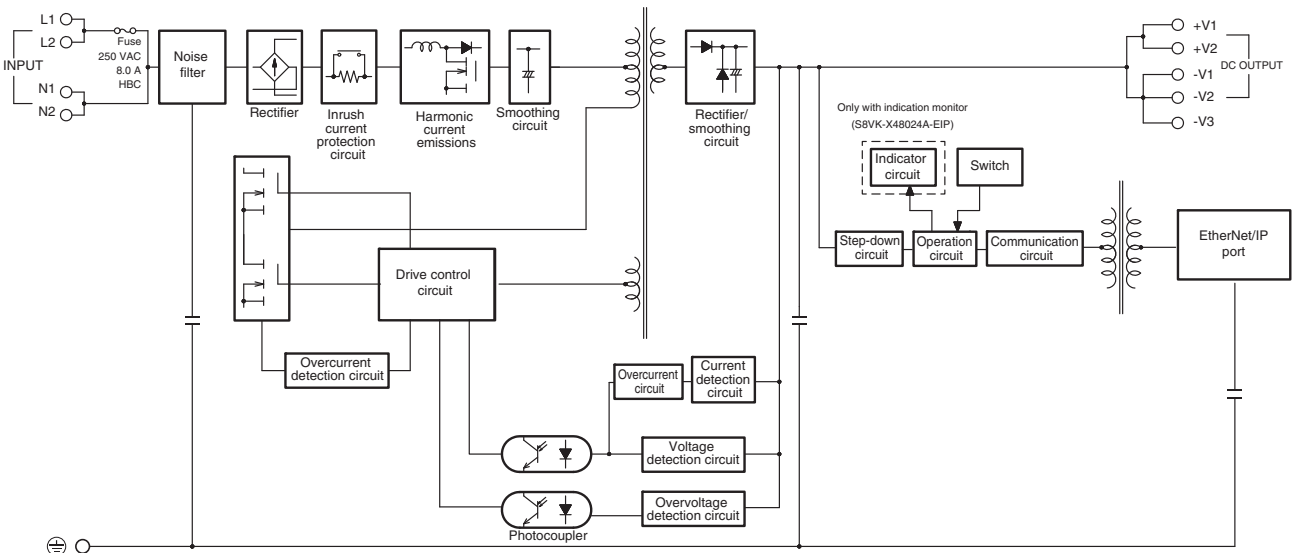

Nomenclature

With Indication Monitor

90 W/120 W

S8VK-X09024A-EIP
S8VK-X12024A-EIP

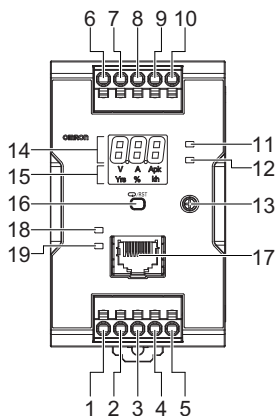

240 W

S8VK-X24024A-EIP

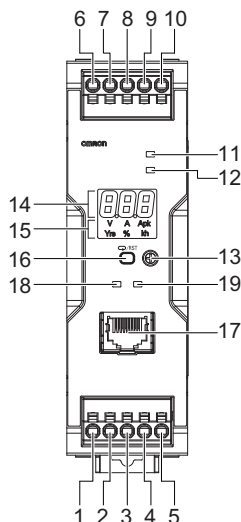

480 W

S8VK-X48024A-EIP

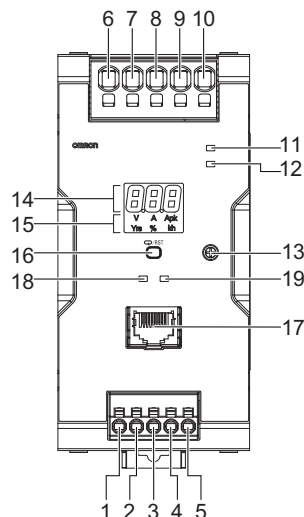

Without Indication Monitor

30 W/60 W

S8VK-X03005-EIP
S8VK-X06012-EIP
S8VK-X06024-EIP

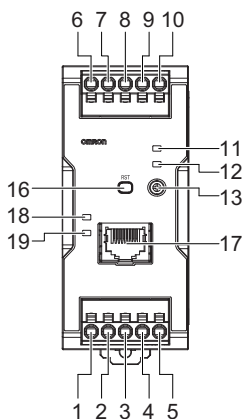

90 W/120 W

S8VK-X09024-EIP
S8VK-X12024-EIP

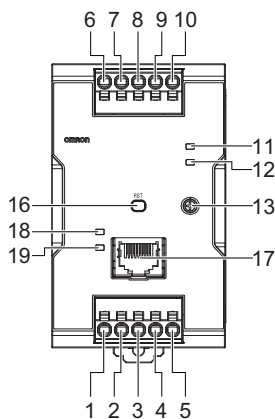

240 W

S8VK-X24024-EIP

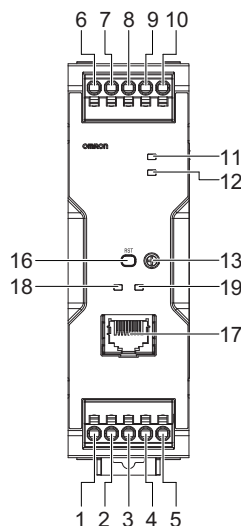

480 W

S8VK-X48024-EIP

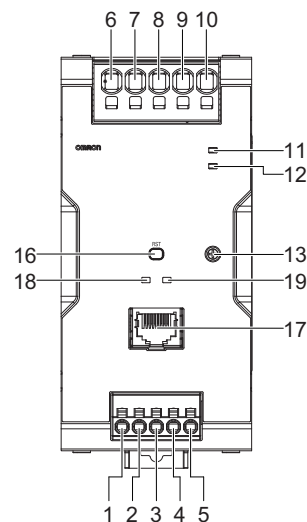

No.	Terminal name	Name	Function	
1	L1	Input terminals	Connect the input lines to these terminals. * 1	
2	L2			
3	N1			
4	N2			
5	PE	Protective Earth terminal (PE)	Connect the ground line to this terminal. * 2	
6	+V1	DC Output terminals	Connect the load lines to these terminals.	
7	+V2			
8	-V1			
9	-V2			
10	-V3			
11	---	Output indicator (DC ON: Green)	The green indicator indicates when a DC voltage is being output.	
12	---	Alarm indicator (ALM: Red)	Lights up in red when a Power Supply abnormality occurs. Refer to <i>Self-Diagnostics Function</i> on page 12 for details.	
13	---	Output voltage adjuster (V. ADJ)	Use to adjust the output voltage.	
14	---	Main display (white)	Displays measured values.	
15	---	Operation indicator (white)	V	Lights up when the output voltage is indicated.
	---		A	Lights up during indication of output current.
	---		Apk	Lights up during indication of peak hold current.
	---		Yrs	Lights up during replacement time calculation year indication.
	---		%	Lights up during years until replacement time indication.
	---		kh	Lights up during percentage until replacement time indication.
16	---	Indication switching/reset key (types with indication monitor) Reset key (types without indication monitor)	Used to change the indicated parameter. Used to reset the peak hold current or communication settings. For reset methods, refer to <i>Communication Reset Function</i> on page 10.	
17	---	EtherNet/IP port	Connects to EtherNet cables.	
18	---	Module status indicator (MS)	Refer to <i>Module Status and Network Status Indicators</i> on page 10 for details.	
19	---	Network status indicator (NS)		

*1. The fuse is located on the (L) side. For a DC input, connect the positive voltage to the L terminal.

*2. This is the protective earth terminal specified in the safety standards. Always ground this terminal.

Engineering Data

Derating Curves

Horizontal separation: 15 mm or more

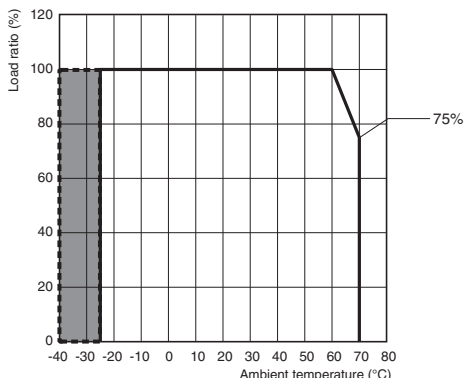

- Note:**
- 1%*V* derating at less than 100 VAC
 - 0.5%*V* derating at less than 140 VDC
 - In the shaded area, time is required to reach the rated output voltage after the input voltage is applied. Also, the ripple noise value in this area may exceed the range given on page 3 to 5.

A: Standard mounting, mounted with side-mounting brackets (30 W, 60 W), or mounted with front-mounting brackets (30 W, 60 W, 240 W, 480 W)

Horizontal separation: Less than 15 mm

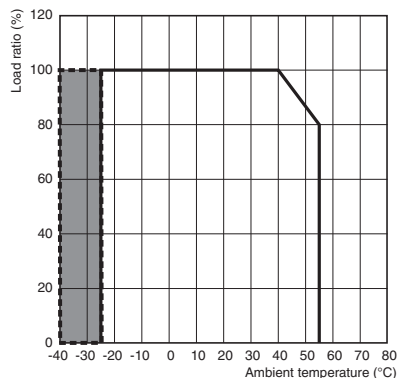

- Note:**
1. Apply the rated voltage.
 - In the shaded area, time is required to reach the rated output voltage after the input voltage is applied. Also, the ripple noise value in this area may exceed the range given on page 3 to 5.

B: Front, side-by-side mounting

This Power Supply can be used at an altitude of 3,000 m. Between 2,000 and 3,000 m, derate the load according to the following derating curve.

Horizontal separation: 15 mm or more

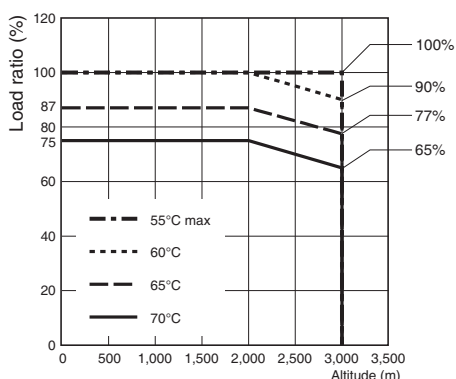

- Note:**
- 1%*V* derating at less than 100 VAC
 - 0.5%*V* derating at less than 140 VDC

A: Standard mounting, mounted with side-mounting brackets (30 W, 60 W), or mounted with front-mounting brackets (30 W, 60 W, 240 W, 480 W)

Horizontal separation: Less than 15 mm

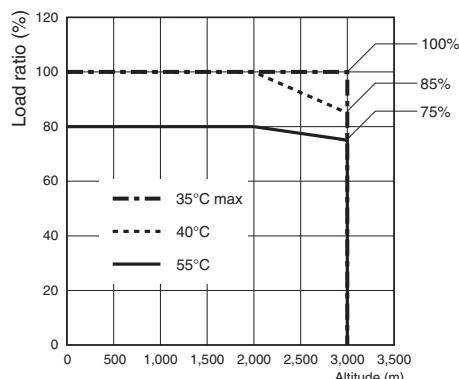

Note: Apply the rated voltage.

B: Front, side-by-side mounting

S8VK-X

Dimensions

(Unit: mm)

Unit

S8VK-X03005-EIP (30 W)
S8VK-X06012-EIP (60 W)
S8VK-X06024-EIP (60 W)

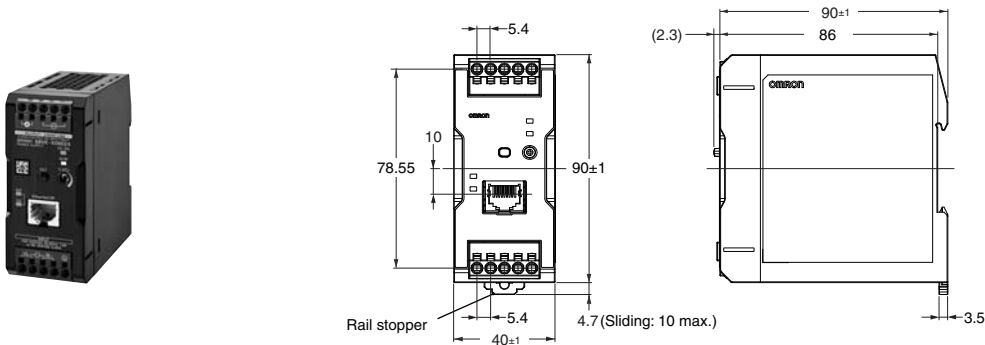

The above diagram shows S8VK-X06024-EIP.

S8VK-X09024□-EIP (90 W)
S8VK-X12024□-EIP (120 W)

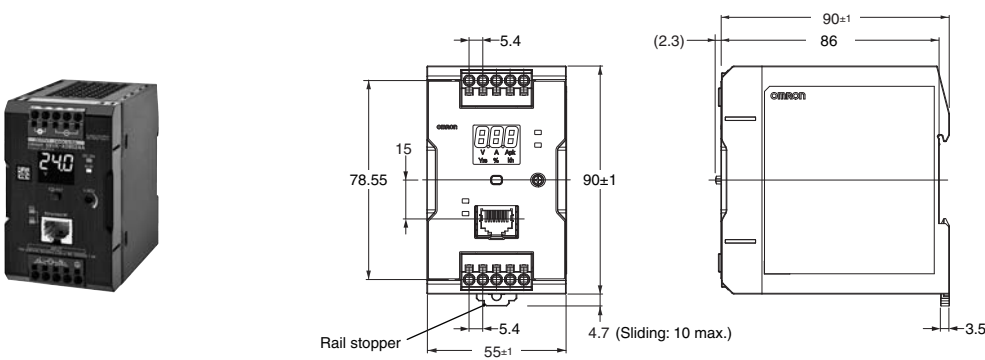

The above diagram shows S8VK-X09024A-EIP.

S8VK-X24024□-EIP (240 W)

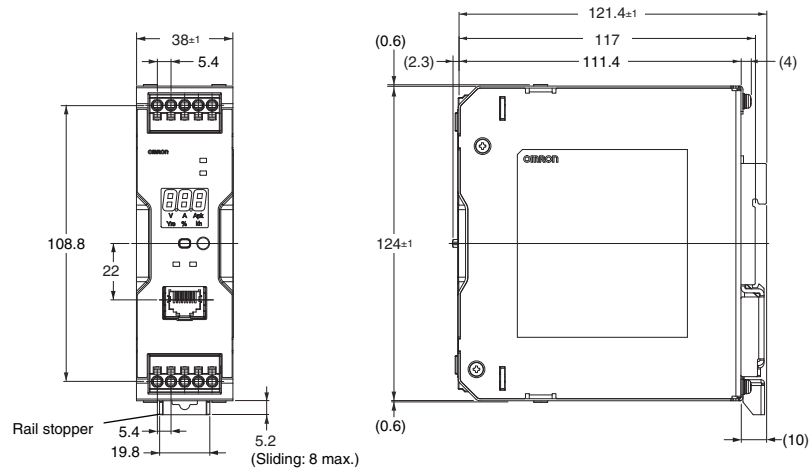

The above diagram shows S8VK-X24024A-EIP.

S8VK-X48024□-EIP (480 W)

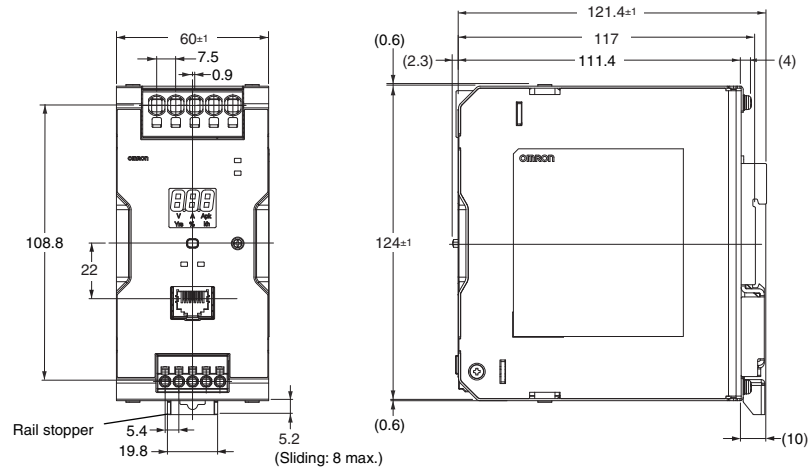

The above diagram shows S8VK-X48024A-EIP.

S8VK-X

Name	Model number	Dimensions	Appearance
Front-mounting bracket (For 30 W and 60 W models)	S82Y-VS10F		
Side-mounting bracket (For 30 W and 60 W models)	S82Y-VS10S		Left-side mounting Right-side mounting
Front-mounting bracket (For 240 W and 480 W models)	S82Y-VK10F	<p>240 W Three locations Mounting screw tightening torque: 0.5 to 0.6 N·m</p> <p>480 W Four locations Mounting screw tightening torque: 0.5 to 0.6 N·m</p> <p>Be sure to use the accessory screws.</p>	

DIN Rail Mounting (Order Separately)

Mounting Rail (Material: Aluminum)

PFP-100N
PFP-50N

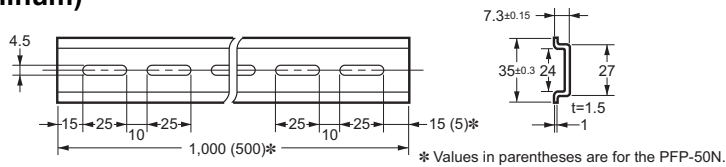
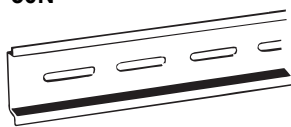

Mounting Rail (Material: Aluminum)

PFP-100N2

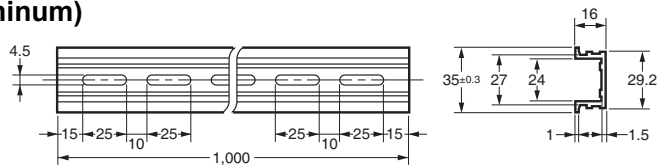
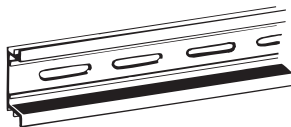

End Plate

PFP-M

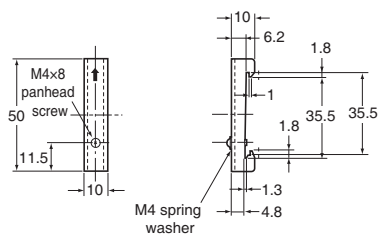
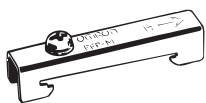





- Note:**
1. If there is a possibility that the Unit will be subject to vibration or shock, use a steel DIN Rail. Otherwise, metallic filings may result from aluminum abrasion.
 2. If the Unit may be subjected to sliding to either side, attach an End Plate (model PFP-M) on each side of the Unit.

Safety Precautions

Warning Indications

 WARNING	Indicates a potentially hazardous situation which, if not avoided, will result in minor or moderate injury, or may result in serious injury or death. Additionally, there may be significant property damage.
 CAUTION	Indicates a potentially hazardous situation which, if not avoided, may result in minor or moderate injury or in property damage.
Precautions for Safe Use	Supplementary comments on what to do or avoid doing, to use the product safely.
Precautions for Correct Use	Supplementary comments on what to do or avoid doing, to prevent failure to operate, malfunction or undesirable effect on product performance.

Meaning of Product Safety Symbols

	Used to warn of the risk of electric shock under specific conditions.
	Used to warn of the risk of minor injury caused by high temperatures.
	Used to indicate prohibition when there is a risk of minor injury from electrical shock or other source if the product is disassembled.
	Used for general mandatory action precautions for which there is no specified symbol.

WARNING

The electrical wire may come out and an electric shock may be caused. Insert the solid wire or ferrule straight into the terminal block until the end touches the terminal block.



CAUTION

Minor electric shock, fire, or Product failure may occasionally occur. Do not disassemble, modify, or repair the Product or touch the interior of the Product.



Minor burns may occasionally occur. Do not touch the Product while power is being supplied or immediately after power is turned OFF.



Minor injury due to electric shock may occasionally occur. Do not touch the terminals while power is being supplied.



Minor electric shock, fire, or Product failure may occasionally occur. Do not allow any pieces of metal, conductors, or cuttings from installation work to enter the Power Supply.



Precautions for Safe Use

Ambient Operating and Storage Environments

- Store the Power Supply at a temperature of -40 to 85°C and a humidity of 95% or less.
- To maintain performance of the replacement time calculation functions, make sure the following conditions are satisfied for long-term storage. For storage exceeding three months, keep the Product at a temperature of -25 to 30°C and a relative humidity of 25 to 70%.
- Do not use the Power Supply in areas outside the derating curve as doing so may result in internal parts occasionally deteriorating or being damaged.
- Use the Power Supply at a humidity of 95% max.
- Do not use the Power Supply in locations subject to direct sunlight.
- Do not use locations where liquids, foreign matter, or corrosive gases may enter the interior of the Product.

Installation Environment

- Do not use the Product in locations subject to shocks or vibrations. In particular, install the Power Supply as far away as possible from contactors or other devices that are a vibration source.
- Install the Power Supply well away from any sources of strong, high-frequency noise and surge.

Mounting

- Take adequate measures to ensure proper heat dissipation to increase the long-term reliability of the Power Supply. Be sure to allow convection in the atmosphere around devices when mounting. Do not use in locations where the ambient temperature exceeds the range of the derating curve.
- When cutting out holes for mounting, make sure that cuttings do not enter the interior of the Power Supplies.
- The internal parts may occasionally deteriorate and be broken due to adverse heat radiation. Do not loosen the screws on the Power Supply.

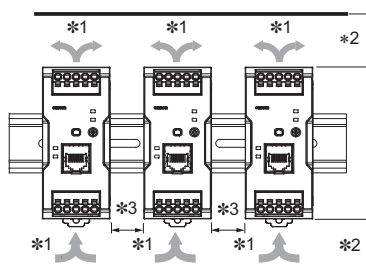

- *1. Convection of air
- *2. Vertical separation:
25 mm or more
(S8VK-X03005-EIP,
X060-EIP,
X09024-EIP,
X12024-EIP)
Vertical separation:
23 mm or more
(S8VK-X24024-EIP,
X48024-EIP)
- *3. Horizontal separation:
15 mm or more
(Standard mounting)
Horizontal separation:
Less than 15 mm
(Front, side-by-side
mounting)

- S8VK-X can be used in combinations with a horizontal separation of less than 15 mm (front, side-by-side mounting) only in cases of the same model being used. In such cases, use the product in accordance with a derating curve with a horizontal separation of less than 15 mm.

Mounting

(A) Standard (vertical) mounting

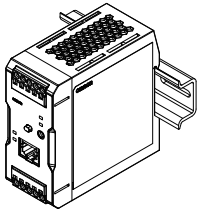

(B) Front, side-by-side mounting

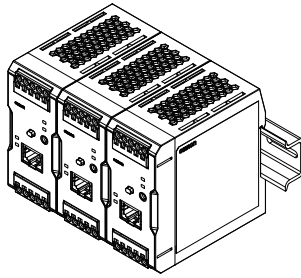

Wiring

- Connect the ground completely. A protective earthing terminal stipulated in safety standards is used. Electric shock or malfunction may occur if the ground is not connected completely.
- Minor fire may possibly occur. Ensure that input and output terminals are wired correctly.
- When you insert wires or insert a screwdriver into a release hole, do not press down on the terminal block with a force of 40 N or greater.
- Do not wire anything to the release holes.
- Do not tilt or twist a flat-blade screwdriver while it is inserted into a release hole on the terminal block. The terminal block may be damaged.
- Insert a flat-blade screwdriver into the release holes at an angle. The terminal block may be damaged if you insert the screwdriver straight in.
- Do not allow the flat-blade screwdriver to fall out while it is inserted into a release hole.
- Do not bend a wire past its natural bending radius or pull on it with excessive force. This may cause a wire to be broken.
- Do not insert more than one wire into each terminal insertion hole.
- Do not pre-solder the ends of the wires. Doing so will inhibit proper connection.
- Be sure to remove the sheet covering the S8M for machining before power-ON so that it does not interfere with heat dissipation.
- If there is a possibility of vibration or shock, please use wires and stranded wires with ferrules.

- Use the following material for the wires after confirming the rating of the wires in order to prevent smoking or ignition.

Recommended Wire Type

Terminal	Model number	Recommended wire gauge	
		(mm ²)	(AWG)
Input	S8VK-X03005-EIP, X06012-EIP, X06024-EIP, X09024□-EIP, X12024□-EIP	0.34 to 2.5	22 to 14
	S8VK-X24024□-EIP	0.5 to 2.5	20 to 14
	S8VK-X48024□-EIP	0.75 to 2.5	18 to 14
Output	S8VK-X03005-EIP	0.75 to 2.5	18 to 14
	S8VK-X06012-EIP	0.75 to 2.5	18 to 14
	S8VK-X06024-EIP	0.5 to 2.5	20 to 14
	S8VK-X09024□-EIP	0.5 to 2.5	20 to 14
	S8VK-X12024□-EIP	0.75 to 2.5	18 to 14
	S8VK-X24024□-EIP	2 to 2.5	14
	S8VK-X48024□-EIP	3.5 to 6	12 to 10
PE (protective earth) terminal	S8VK-X03005-EIP, X06012-EIP, X06024-EIP, X09024□-EIP, X12024□-EIP, X24024□-EIP, X48024□-EIP	2 to 2.5	14

- Input crossover wiring can be used for the input side of this Power Supply.
- Do not use crossover wiring for more than five Power Supplies, and do not allow the steady-state current to the input terminals to exceed 10 A. The above table gives the recommended wires for one Power Supply.
- If you use crossover wiring for N number of Power Supplies, a current that is N times the current for a standalone Power Supply may flow to the input terminals. Take this into consideration when you select wiring materials.

Stripping Length

S8VK-X03005-EIP, S8VK-X06012-EIP, S8VK-X06024-EIP, S8VK-X09024□-EIP, S8VK-X12024□-EIP, S8VK-X24024□-EIP

: Input and output terminals

S8VK-X48024□-EIP: Input terminals

Recommended wire gauge	Stripping length (Ferrules not used)
0.34 to 1.5 mm ² / AWG22 to 16	8 mm
2 to 2.5 mm ² /AWG14	10 mm

S8VK-X48024□-EIP: Output terminals

Recommended wire gauge	Stripping length (Ferrules not used)
3.5 to 6 mm ² / AWG12 to 10	15 mm

Power Boost Function

The boost current is a temporary current that exceeds the rated current.

However, it should meet the following four boost current conditions.

- Time that the boost current flows: $t_1 \leq 10$ s
- The boost current: $I_p \leq$ Maximum boost current
- The average output current: $I_{ave} \leq$ Rated output current
- The time ratio of the boost current flow: Duty $\leq 30\%$

$$\text{Duty} = \frac{t_1}{t_1 + t_2} \times 100 [\%] \leq 30\%$$

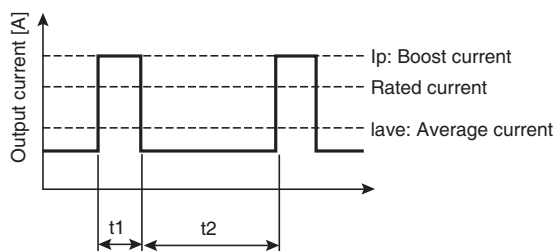

- Do not allow the boost current to continue for more than 10 seconds. Do not allow the duty to exceed 30%. The Power Supply may be damaged.
- Ensure that the average current of one cycle of the boost current does not exceed the specified value. The Power Supply may be damaged.
- Derate the load at the boost current and average output current according to the ambient operating temperature and mounting.

Charging a Battery

If you connect a battery as the load, install overcurrent control and overvoltage protection circuits.

Output voltage adjuster (V. ADJ.)

- The output voltage adjuster (V. ADJ.) may possibly become damaged. Do not apply more than the required force.
- After completing output voltage adjustment, be sure that the output power or output current does not exceed the rated output electric power or rated output current.

Series Operation

Two Power Supplies can be connected in series.

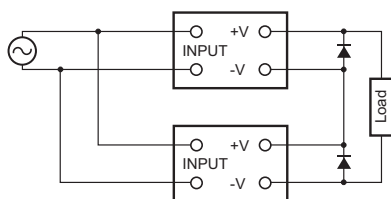

Note: 1. If the load is short-circuited, a reverse voltage will be generated inside the Power Supply. If this occurs the product may possibly deteriorate or be damaged. Always connect a diode as shown in the figure. Select diodes with the following ratings.

Type	Schottky Barrier diode
Dielectric strength (VRRM)	Twice the output voltage or above
Forward current (If)	Twice the rated output current or above

Note: 2. Though Power Supplies having different specifications can be connected in series, the current flowing through the load must not exceed the smaller rated output current.

Making Positive/Negative Outputs

- The outputs are floating outputs (i.e., the primary circuits and secondary circuits are separated). You can therefore make positive and negative outputs by using two Power Supplies. If positive and negative outputs are used, connect Power Supplies of the same series as in the following figure. (Combinations with different output capacities or output voltages can be made. However, use the lower of the two maximum rated output currents as the current to the loads.)

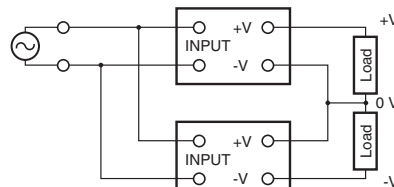

- Depending on the model, internal circuits may be damaged due to startup failure when the power is turned ON if loads such as a servomotor or operational amplifier may operate in series. Therefore, connect bypass diodes (D1, D2) as shown in the following figure.

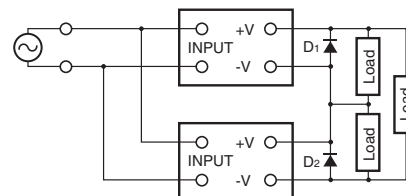

- Use the following information as a guide to the diode type, dielectric strength, and current.

Type	Schottky Barrier diode
Dielectric strength (VRRM)	Twice the output voltage or above
Forward current (If)	Twice the rated output current or above

Parallel Operation

Parallel operation is used when the output current from one Power Supply is insufficient for the load. Power Supplies are connected in parallel to increase the output current. Two Power Supplies can be connected in parallel.

You must meet the following conditions to use parallel operation.

- Rated input voltage range
- Output voltage
 - 25 V or less: (S8VK-X□□□24□-EIP)
 - 12.5 V or less: (S8VK-X06012-EIP)
 - 5.2 V or less: (S8VK-X03005-EIP)
- Output current per unit
 - 100% or less of the rated output current (excluding S8VK-X060□□-EIP and S8VK-X03005-EIP)
 - 80% or less of the rated output current (S8VK-X060□□-EIP and S8VK-X03005-EIP)
- Ambient temperature: -25 to 40°C
- Standard mounting.
- Horizontal separation: 15 mm or more
- Vertical separation: 25 mm or more (excluding S8VK-X24024□-EIP and S8VK-X48024□-EIP) 23 mm or more (S8VK-X24024□-EIP and S8VK-X48024□-EIP)

- Adjust the output voltage difference of each Power Supply to 50 mV or less, using the output voltage adjuster (V. ADJ).
- There is no current balancing function for S8VK-X. A high output voltage unit may work at overcurrent state and in this situation, a life of a Power Supply will be extremely short. After adjusting the output voltage, confirm the output current of the Power Supplies balances.
- During parallel operation, UL1310 Class 2 output and UL 60950-1, UL 62368-1, EN 60950-1, and EN62368-1 LPS output are excluded.
- For Parallel Operation, to balance the current of the each unit, the length and thickness of each wire connected to the load and each unit must be same as much as possible.
- If you use the output voltage may drop by several volts if the load changes rapidly (e.g., if the load starts or is disconnected). Use the S8VK-R or connect external diodes as shown in the figure. For parallel operation with 30 W, 60 W, 90 W or 120 W Power Supplies, use the S8VK-R10. For parallel operation with 240 W Power Supplies, use the S8VK-R20.
- Do not use parallel operation when there is the possibility that the input voltage will vary outside of the rated input range.

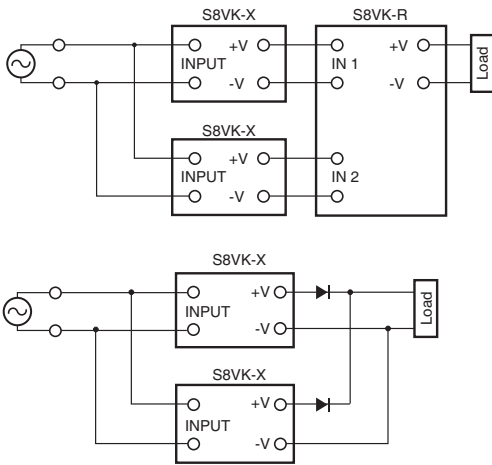

- Use the following information as a guide to the diode type, dielectric strength, and current.

Type	Schottky Barrier diode
Dielectric strength (VRRM)	Twice the output voltage or above
Forward current (IF)	Twice the rated output current or above

<Backup Operation>

Backup operation is possible if you use two Power Supplies of the same model.

Even if one Power Supply fails, operation can be continued with the other Power Supply.

Make sure that the maximum load does not exceed the capacity of one Power Supply.

Use the S8VK-R or connect external diodes.

For backup operation with 30 W, 60 W, 90 W or 120 W Power Supplies, use the S8VK-R10. For backup operation with 240 W Power Supplies, use the S8VK-R20.

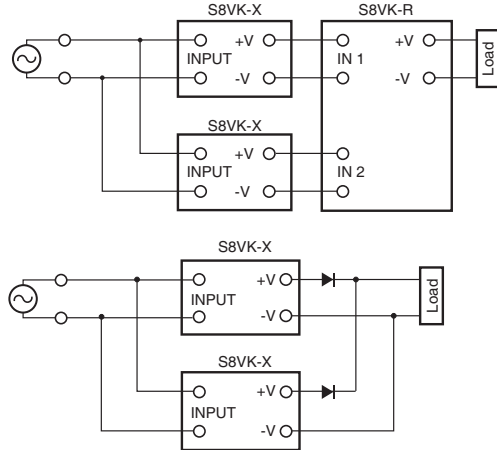

- Use the following information as a guide to the diode type, dielectric strength, and current.

Type	Schottky Barrier diode
Dielectric strength (VRRM)	Twice the output voltage or above
Forward current (IF)	Twice the rated output current or above

Two phases application for Single phase models

For All Single phase Models, S8VK-X

Basically OMRON single phase power supply can be used on two-phases of a 3-phase-system when some of conditions satisfy like below.

- The supplying voltage is below the maximum rated input. OMRON Power supply allows the input voltage equivalent or less than 240 VAC+10%. Please confirm the input voltage between two lines if the input voltage satisfies this condition before connecting.
- The external protector is needed on N input line to secure a safety. N line has no protection of a fuse internally. An appropriate fuse or circuit breaker should be connected on N input line like the following.

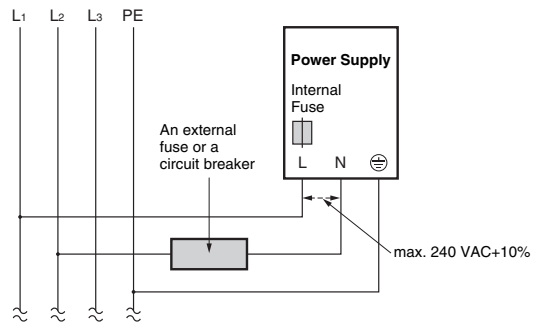

Precautions for Correct Use

DIN Rail Mounting

30 W/60 W/90 W/120 W

To mount the Block on a DIN Rail, hook portion (A) of the Block onto the rail and press the Block in direction (B).

240 W/480 W

To mounting on a DIN Rail, hook portion (A) of the Block onto the rail and press in the (B) direction.

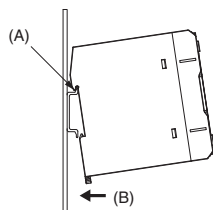

To dismantle the Block, pull down portion (C) with a flat-blade screwdriver and pull out the Block.

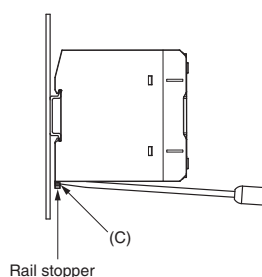

Connecting Wires to the Push-In Plus Terminal Block

Part Names of the Terminal Block

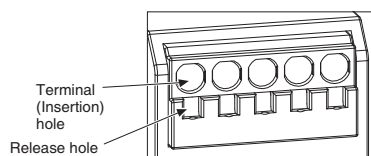

Connecting Wires with Ferrules and Solid Wires

Insert the solid wire or ferrule straight into the terminal block until the end touches the terminal block.

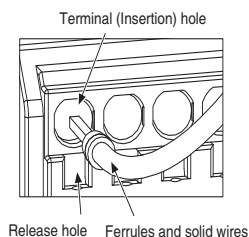

- If a wire is difficult to connect because it is too thin, use a flat-blade screwdriver in the same way as when connecting stranded wire.

Connecting Stranded Wires

Use the following procedure to connect the wires to the terminal block.

1. Hold a flat-blade screwdriver at an angle and insert it into the release hole.
The angle should be between 10° and 15°. If the flat-blade screwdriver is inserted correctly, you will feel the spring in the release hole.
2. With the flat-blade screwdriver still inserted into the release hole, insert the wire into the terminal hole until it strikes the terminal block.
3. Remove the flat-blade screwdriver from the release hole.

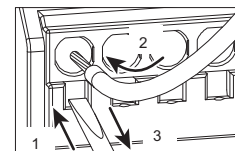
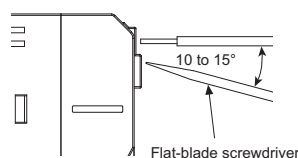

Checking Connections

- After the insertion, pull gently on the wire to make sure that it will not come off and the wire is securely fastened to the terminal block.
- The insulation distance is still satisfied although some of the conductor may still be visible after being inserted into the terminal block, even though the recommended ferrule is used.

Removing Wires from the Push-In Plus Terminal Block

Use the following procedure to remove wires from the terminal block. The same method is used to remove stranded wires, solid wires, and ferrules.

1. Hold a flat-blade screwdriver at an angle and insert it into the release hole.
2. With the flat-blade screwdriver still inserted into the release hole, remove the wire from the terminal insertion hole.
3. Remove the flat-blade screwdriver from the release hole.

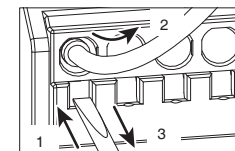
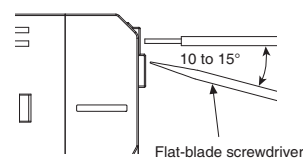

Recommended Ferrules and Crimping Tools

Recommended Ferrules

S8VK-X03005-EIP, X06012-EIP, X06024-EIP

S8VK-X09024-EIP, X12024-EIP, X24024-EIP

Input and Output Terminals

S8VK-X48024-EIP: Input Terminals

Applicable wire		Ferrule Conductor length (mm)	Stripping length (mm) (Ferrules used)	Recommended ferrules		
(mm ²)	(AWG)			Manufactured by Phoenix Contact	Manufactured by Weidmuller	Manufactured by Wago
0.34	22	8	10	AI 0,34-8	H0.34/12	216-302
		10	12	AI 0,34-10	---	---
0.50	20	8	10	AI 0,5-8	H0.5/14	216-201
		10	12	AI 0,5-10	H0.5/16	216-241
0.75	18	8	10	AI 0,75-8	H0.75/14	216-202
		10	12	AI 0,75-10	H0.75/16	216-242
1/1.25	18/17	8	10	AI 1-8	H1.0/14	216-203
		10	12	AI 1-10	H1.0/16	216-243
1.25/1.5	17/16	8	10	AI 1,5-8	H1.5/14	216-204
		10	12	AI 1,5-10	H1.5/16	216-244
2.5	14	10	12	AI 2,5-10	H2.5/16DS	216-246
Recommended crimp tool				CRIMPFOX6 CRIMPFOX6T-F CRIMPFOX10S	PZ6 roto	Variocrimp4

- Note:** 1. Make sure that the outer diameter of the wire is smaller than the inner diameter of the insulating sleeve of the recommended ferrule.
2. Make sure that the ferrule processing dimensions conform to the following figure.

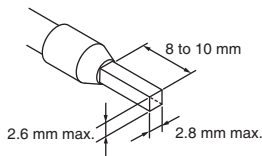

S8VK-X48024-EIP: Output Terminals

Applicable wire		Ferrule Conductor length (mm)	Stripping length (mm) (Ferrules used)	Recommended ferrules		
(mm ²)	(AWG)			Manufactured by Phoenix Contact	Manufactured by Weidmuller	Manufactured by Wago
3.5	12	12	14	AI 4-12	H4.0/20D	216-267
6	10	12	16	AI 6-12	H6.0/20	216-208 *
Recommended crimp tool				CRIMPFOX6 CRIMPFOX6T-F CRIMPFOX10S	PZ6 roto	Variocrimp4 * Use the Variocrimp16.

- Note:** 1. Make sure that the outer diameter of the wire is smaller than the inner diameter of the insulating sleeve of the recommended ferrule.
2. Make sure that the ferrule processing dimensions conform to the following figure.

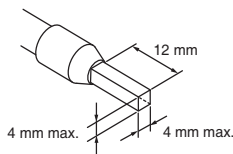

Recommended Flat-blade Screwdriver

Use a flat-blade screwdriver to connect and remove wires. Use the following flat-blade screwdriver.

The following table shows manufacturers and models as of 2018/Dec.

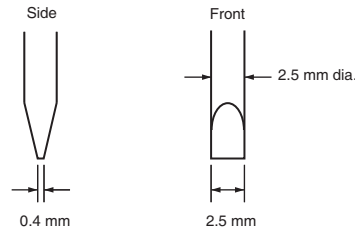

Model number	Manufacturer
ESD 0,40x2,5	Wera
SZS 0,4x2,5 SZF 0-0,4x2,5 *	Phoenix Contact
0.4x2.5x75 302	Wiha
AEF.2,5x75	Facom
210-719	Wago
SDIS 0.4x2.5x75	Weidmuller
9900(-2.5x75)	Vessel

* OMRON's exclusive purchase model XW4Z-00B is available to order as SZF 0-0,4x2,5 (manufactured by Phoenix Contact).

Audible Noise at Power ON

<S8VK-X12024-EIP, -X24024-EIP, -X48024-EIP>

A harmonic current suppression circuit is built into the Power Supply. This circuit can create noise when the input is turned ON, but it will last only until the internal circuits stabilize and does not indicate any problem in the Product.

Communication

- Communication settings are required when installing/replacing. Set according to the *S8VK-X Communication Manual* (Man. No. T213).
- For details on the EtherNet/IP, Modbus TCP connection method or cable to be used, refer to the *S8VK-X Communication Manual* (Man. No. T213). This may cause a communication error to occur.
- Ensure that communication distance within the usage range.
- If performing EtherNet/IP tag data link communication (cyclic communication) using a repeater hub, the communication load of the network will increase, increasing the number of collisions and making stable communication impossible. Make sure to use switching hubs for networks using tag data links.

Communication Cables

- Do not bend a communication cable past its natural bending radius or pull on it with excessive force. Do not place heavy objects on the cord. This may cause a wire to be broken.
- Separate the communication cable into a high voltage and high current power line to prevent induction noise. Additionally, avoid parallel wiring with or using the same wire as the power line. It is effective to separate piping and ducts.
- If no communication cable is connected, attach a dust cover.
- Depending on the ambient temperature or load ratio, the Power Supply may get extremely hot. In that case, minor burns may occur. Do not insert and remove communications cables.
- A tag data link timeout may occur with products manufactured on or before February 28, 2019, over a network system including nodes set for multicast communications. Use the multicast blocking function of the switching hub to prevent multicast packets from reaching the S8VK-X. Please contact your OMRON representative for more information.
- When you use tag data link, explicit message communications, and Modbus message communications simultaneously, limit the number of client nodes to 4 or less. If simultaneous communication is carried out with 5 or more nodes, a timeout may occur due to the communications load.

In Case There Is No Output Voltage

The possible cause for no output voltage may be that the overload protection or overvoltage protection has operated. The internal protection may operate if a large amount of surge voltage, such as a lightning inrush, is applied to the input.

In case there is no output voltage, please check the following points before contacting us:

Checking overload protected status:

Check whether the load is in overload status or is short-circuited. Remove the load wires when checking.

Checking overvoltage or internal protection:

Switch off the input power supply, and switch back on after at least 3 minutes have elapsed.

Period and Terms of Warranty

Warranty Period

The Power Supply warranty is valid for a period of Five years from the date of shipment from the factory.

Terms of Warranty

The warranty is valid only for the following operating conditions.

1. Average ambient operating temperature of the Power Supply: 40°C max.
2. Average load rate of 80% max.
3. Mounting method: Standard mounting

Note: The maximum ratings must be within the derating curve.

If the Power Supply fails for reasons attributable to OMRON within the above warranty period, OMRON will repair or replace the faulty part of the Power Supply at the place of purchase or the place where the Power Supply delivered without charge.

This warranty does not cover the following types of failures.

- (1) Failures that result from handling or operation of the Power Supply under conditions or in environments that are not given in this document and not given in any other specifications exchanged between OMRON and the customer
- (2) Failures that originate in causes other than the delivered product itself
- (3) Failures caused by disassembly, modification, or repair of the Power Supply by anyone other than OMRON
- (4) Failures caused by applications or uses for which the Power Supply was not originally intended.
- (5) Failures caused by factors that could not be anticipated with the scientific or technical knowledge available when the Power Supply was shipped.
- (6) Failures caused by other causes for which OMRON is not responsible, such as natural disasters and other acts of God.
This warranty is limited to the individual Power Supply that was delivered and does not cover any secondary, subsequent, or related damages.

Recommended Replacement Periods and Periodic Replacement for Preventive Maintenance

The recommended replacement period for preventive maintenance is greatly influenced by the application environment of the Power Supply. As a guideline, the recommended replacement period is 7 to 10 years.*

S8VK-X is equipped with a replacement time calculation function, and the approximate number of years until replacement based on the ambient temperature and load rate can be checked via indicator (types with indication monitors only) or communication.

To prevent failures or accidents that can be caused by using a Power Supply beyond its service life, we recommend that you replace the Power Supply as early as possible within the recommended replacement period.

However, bear in mind that the recommended replacement period is for reference only and does not guarantee the life of the Power Supply.

Many electronic components are used in the Power Supply and the Power Supply depends on the correct operation of these components to achieve the original Power Supply functions and performance. However, the influence of the ambient temperature on aluminum electrolytic capacitors is large, and the service life is reduced by half for each 10°C rise in temperature (Arrhenius law). When the capacity reduction life of the electrolytic capacitor is reached, the Power Supply failures or accidents may occur. We therefore recommend that you replace the Power Supply periodically to minimize product failures or accidents in advance.

* The recommended replacement period applies under the following conditions: rated input voltage, load rate of 50% max., ambient temperature of 40°C max., and the standard mounting method.

This product model is designed with a service life of 10 years minimum under the above conditions.

Terms and Conditions Agreement

Read and understand this catalog.

Please read and understand this catalog before purchasing the products. Please consult your OMRON representative if you have any questions or comments.

Warranties.

- (a) Exclusive Warranty. Omron's exclusive warranty is that the Products will be free from defects in materials and workmanship for a period of twelve months from the date of sale by Omron (or such other period expressed in writing by Omron). Omron disclaims all other warranties, express or implied.
- (b) Limitations. OMRON MAKES NO WARRANTY OR REPRESENTATION, EXPRESS OR IMPLIED, ABOUT NON-INFRINGEMENT, MERCHANTABILITY OR FITNESS FOR A PARTICULAR PURPOSE OF THE PRODUCTS. BUYER ACKNOWLEDGES THAT IT ALONE HAS DETERMINED THAT THE PRODUCTS WILL SUITABLY MEET THE REQUIREMENTS OF THEIR INTENDED USE.

Omron further disclaims all warranties and responsibility of any type for claims or expenses based on infringement by the Products or otherwise of any intellectual property right. (c) Buyer Remedy. Omron's sole obligation hereunder shall be, at Omron's election, to (i) replace (in the form originally shipped with Buyer responsible for labor charges for removal or replacement thereof) the non-complying Product, (ii) repair the non-complying Product, or (iii) repay or credit Buyer an amount equal to the purchase price of the non-complying Product; provided that in no event shall Omron be responsible for warranty, repair, indemnity or any other claims or expenses regarding the Products unless Omron's analysis confirms that the Products were properly handled, stored, installed and maintained and not subject to contamination, abuse, misuse or inappropriate modification. Return of any Products by Buyer must be approved in writing by Omron before shipment. Omron Companies shall not be liable for the suitability or unsuitability or the results from the use of Products in combination with any electrical or electronic components, circuits, system assemblies or any other materials or substances or environments. Any advice, recommendations or information given orally or in writing, are not to be construed as an amendment or addition to the above warranty.

See <http://www.omron.com/global/> or contact your Omron representative for published information.

Limitation on Liability: Etc.

OMRON COMPANIES SHALL NOT BE LIABLE FOR SPECIAL, INDIRECT, INCIDENTAL, OR CONSEQUENTIAL DAMAGES, LOSS OF PROFITS OR PRODUCTION OR COMMERCIAL LOSS IN ANY WAY CONNECTED WITH THE PRODUCTS, WHETHER SUCH CLAIM IS BASED IN CONTRACT, WARRANTY, NEGLIGENCE OR STRICT LIABILITY.

Further, in no event shall liability of Omron Companies exceed the individual price of the Product on which liability is asserted.

Suitability of Use.

Omron Companies shall not be responsible for conformity with any standards, codes or regulations which apply to the combination of the Product in the Buyer's application or use of the Product. At Buyer's request, Omron will provide applicable third party certification documents identifying ratings and limitations of use which apply to the Product. This information by itself is not sufficient for a complete determination of the suitability of the Product in combination with the end product, machine, system, or other application or use. Buyer shall be solely responsible for determining appropriateness of the particular Product with respect to Buyer's application, product or system. Buyer shall take application responsibility in all cases.

NEVER USE THE PRODUCT FOR AN APPLICATION INVOLVING SERIOUS RISK TO LIFE OR PROPERTY OR IN LARGE QUANTITIES WITHOUT ENSURING THAT THE SYSTEM AS A WHOLE HAS BEEN DESIGNED TO ADDRESS THE RISKS, AND THAT THE OMRON PRODUCT(S) IS PROPERLY RATED AND INSTALLED FOR THE INTENDED USE WITHIN THE OVERALL EQUIPMENT OR SYSTEM.

Programmable Products.

Omron Companies shall not be responsible for the user's programming of a programmable Product, or any consequence thereof.

Performance Data.

Data presented in Omron Company websites, catalogs and other materials is provided as a guide for the user in determining suitability and does not constitute a warranty. It may represent the result of Omron's test conditions, and the user must correlate it to actual application requirements. Actual performance is subject to the Omron's Warranty and Limitations of Liability.

Change in Specifications.

Product specifications and accessories may be changed at any time based on improvements and other reasons. It is our practice to change part numbers when published ratings or features are changed, or when significant construction changes are made. However, some specifications of the Product may be changed without any notice. When in doubt, special part numbers may be assigned to fix or establish key specifications for your application. Please consult with your Omron's representative at any time to confirm actual specifications of purchased Product.

Errors and Omissions.

Information presented by Omron Companies has been checked and is believed to be accurate; however, no responsibility is assumed for clerical, typographical or proofreading errors or omissions.

EtherNet/IP™ is the trademarks of ODVA.

Modbus is a registered trademark of Schneider Electric.

Other company names and product names in this document are the trademarks or registered trademarks of their respective companies.

Note: Do not use this document to operate the Unit.

OMRON Corporation Industrial Automation Company

Kyoto, JAPAN

Contact : www.ia.omron.com

Regional Headquarters

OMRON EUROPE B.V.

Wegalaan 67-69, 2132 JD Hoofddorp
The Netherlands
Tel: (31) 2356-81-300 Fax: (31) 2356-81-388

OMRON ELECTRONICS LLC

2895 Greenspoint Parkway, Suite 200
Hoffman Estates, IL 60169 U.S.A.
Tel: (1) 847-843-7900 Fax: (1) 847-843-7787

OMRON ASIA PACIFIC PTE. LTD.

438B Alexandra Road, #08-01/02 Alexandra
Technopark, Singapore 119968
Tel: (65) 6835-3011 Fax: (65) 6835-3011

OMRON (CHINA) CO., LTD.

Room 2211, Bank of China Tower,
200 Yin Cheng Zhong Road,
PuDong New Area, Shanghai, 200120, China
Tel: (86) 21-6023-0333 Fax: (86) 21-5037-2388

Authorized Distributor:

©OMRON Corporation 2017-2024 All Rights Reserved.
In the interest of product improvement,
specifications are subject to change without notice.

CSM_2_2

Cat. No. T210-E1-13 0924 (1117)