

Measuring wheel system

Performance-Line **Double measuring wheel system MWE62** **With spring arm, contact force max. 40 N**



With incremental encoder Sendix KIS50.

Measuring wheel systems from Kübler are the ideal solution for reliable speed measurement, position detection and length measurement in applications with linear movements. These are recorded rotationally via the measuring wheel with attached encoder directly on the surface of the material to be measured and converted into linear data.

The robust MWE62 measuring wheel system offers maximum spring deflection at maximum contact force to compensate for tolerances perpendicular to the transport movement of the material to be measured. The use of 2 measuring wheels always guarantees optimum contact with the material to be measured, even under difficult conditions.

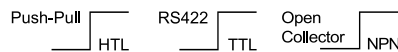

Eigenschaften

- Robust design**
 With flexible mounting options: vertical, horizontal or overhead. Encoder can be mounted on the spring arm in 120° steps.
- High contact reliability to the measured material**
 The use of a second measuring wheel on the encoder ensures a high degree of contact with the measuring surface even under difficult conditions - high vibrations or unevenness.
- Suitable measuring wheels for all measuring surfaces**
 Circumferences 300 mm or 12" – measuring wheel coating available with O-ring or double O-Ring, smooth or corrugated plastic, diamond knurl surface and tufted rubber.
- Contact force up to max. 40 N**
 With stepless adjustable preload. To compensate for tolerances, the integrated spring ensures a working range of the measuring wheel up to a maximum of 80 mm vertical to the measuring surface.

Construction

- 1 Spring arm:** MWE60
- 2 Encoder:** Clamping flange ø 58 mm
- 3 x Measuring wheel:** Circumference 300 mm or 12" (Circumference 200 mm or 500 mm on request)

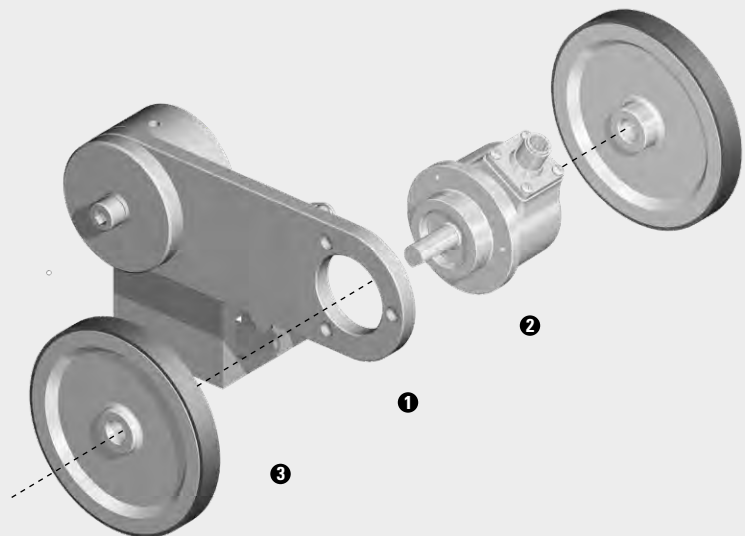

Measuring wheel system

Performance-Line **Double measuring wheel system MWE62** **With spring arm, contact force max. 40 N**





Order code with incremental encoder	8.MWE62 . 1 2 1 . XX . 50 XX . XXXX
<p style="text-align: center; margin: 0;">Type</p> <p>1 <i>Measuring wheel, circumference / coating</i> 31 = 300 mm / diamond knurl (aluminum) 34 = 300 mm / plastic smooth (PU) 36 = 300 mm / tufted rubber (PU) 37 = 300 mm / O-ring (NBR) 38 = 300 mm / double O-ring (NBR) 39 = 300 mm / plastic corrugated (PU)</p> <p>71 = 12" / diamond knurl (aluminum) 74 = 12" / plastic smooth (PU) 76 = 12" / tufted rubber (PU) 77 = 12" / O-Ring (NBR) 78 = 12" / double O-ring (NBR) 79 = 12" / plastic corrugated (PU)</p> <p style="font-size: small;">(Measuring wheels with circumference 200 mm and 500 mm on request)</p>	<p>2 <i>Mounted encoder ¹⁾</i> 50 = KIS50 incremental (other encoders on request)</p> <p>c <i>Output circuit / supply voltage encoder</i> 4 = RS422 / 5 V DC 1 = RS422 / 5 ... 30 V DC 2 = push-pull / 5 ... 30 V DC 5 = push-pull / 10 ... 30 V DC 3 = open collector / 5 ... 30 V DC</p> <p>d <i>Type of connection</i> 2 = radial cable, 1 m [3.28'] PVC R = radial M12 connector, 5-pin 4 = radial M12 connector, 8-pin 8 = radial M23 connector, 12-pin</p> <p>e <i>Pulse rate</i> 100, 120, 200, 250, 256, 300, 360, 500, 512, 600, 1000, 1024, 1200, 2000, 2048, 2500, 3000, 3600, 4096, 5000 (z.B. 100 Impulse => 0100)</p>

Calculation of the linear resolution

	Measuring step (mm/pulse)	Resolution (pulses/mm)
Calculation	$\frac{\text{mm}}{\text{ppr}} = \frac{\text{Measuring wheel circumference}}{\text{Pulse number encoder}}$	$\frac{\text{ppr}}{\text{mm}} = \frac{\text{Pulse number encoder}}{\text{Measuring wheel circumference}}$
Example Measuring wheel circumference = 300 mm Pulse number encoder = 3000 ppr	$\frac{300 \text{ mm}}{3000 \text{ ppr}} = 0.1 \text{ mm / puls}$	$\frac{3000 \text{ ppr}}{300 \text{ mm}} = 10 \text{ pulses / mm}$

1) Clamping flange 58 mm / shaft ø 10 mm on both sides - only relevant when ordering an encoder as a single component.

Measuring wheel system

Performance-Line		Double measuring wheel system MWE62	With spring arm, contact force max. 40 N
Single components			Order no.
Spring arm MWE60 		combinable with Kübler encoders: clamping flange \varnothing 58 mm incremental: Sendix Base KIS50, 5805 absolute: Sendix F58xx, M58xx, 58xx	8.MWE60.121.00.0000.0000
Measuring wheels 		Option ❶ circumference / coating 31 300 mm / diamond knurl (aluminum) 34 300 mm / plastic smooth (PU) 36 300 mm / tufted rubber (PU) 37 300 mm / O-ring (NBR70) 38 300 mm / double O-ring (NBR70) 39 300 mm / plastic corrugated (PU) 71 12" / diamond knurl (aluminum) 74 12" / plastic smooth (PU) 76 12" / tufted rubber (PU) 77 12" / O-ring (NBR70) 78 12" / double O-ring (NBR70) 79 12" / plastic corrugated (PU) <small>(Measuring wheels with circumference 200 mm and 500 mm on request)</small>	8.0000.3317.0010 8.0000.3347.0010 8.0000.3367.0010 8.0000.3377.0010 8.0000.3387.0010 8.0000.3397.0010 8.0000.3717.0010 8.0000.3747.0010 8.0000.3767.0010 8.0000.3777.0010 8.0000.3787.0010 8.0000.3797.0010
Evaluation			Order no.
Preset counter Codix 924 		Multifunction device: - Tachometer with limit values - Position indicators with limit values - Time preset counter	6.924.01XX.XXX
Accessories			Order no.
O-rings 		For measuring wheels with O-ring: Measuring wheel circumference 300 mm, ❶ = 37 Measuring wheel circumference 12", ❶ = 77 For measuring wheels with double O-ring: Measuring wheel circumference 300 mm, ❶ = 38 Measuring wheel circumference 12", ❶ = 78	8.0000.7000.0074 8.0000.7000.0075 8.0000.7000.0077 8.0000.7000.0078

Further accessories can be found at: kuebler.com/accessories
 Cables and connectors can be found at: kuebler.com/connection-technology

Measuring wheel system

Performance-Line **Double measuring wheel system MWE62** **With spring arm, contact force max. 40 N**

Technology in detail

Mounting

The encoder is attached to the spring arm with 3 screws.



For a flexible outlet direction of the cable or connector, the encoder can additionally be mounted in 120° steps.

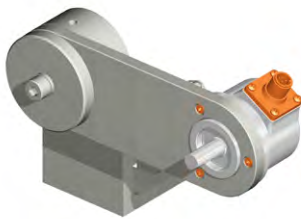

0° (delivery state)



120°



240°

Various mounting options

downwards

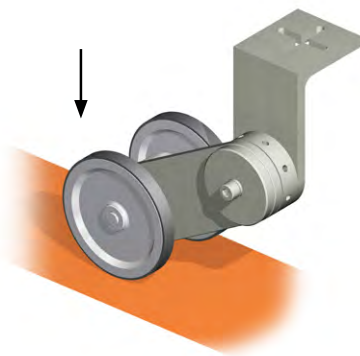

sideways



upwards (overhead)

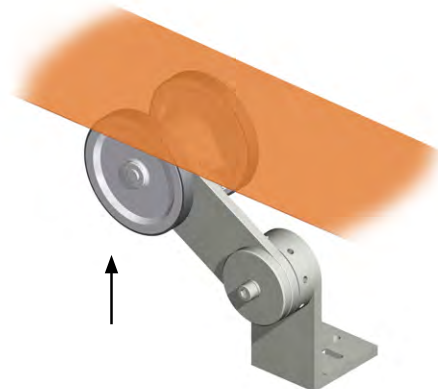

Measuring wheel system

Performance-Line **Double measuring wheel system MWE62** **With spring arm, contact force max. 40 N**

Technology in detail

Setting the preload

1. Mount the measuring wheel system on the application and release screw.
2. Turn the adjustment ring with a thin allen key or screwdriver until the desired preload is reached.
3. As a guide: Internal detent points in 45° steps correspond to approx. 20 N. Hold the position of the adjustment ring and tighten the screw again.

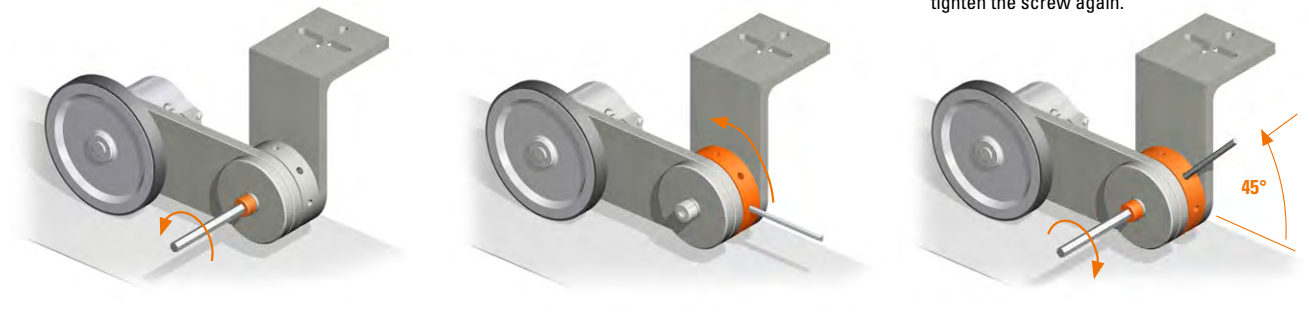

Installation example

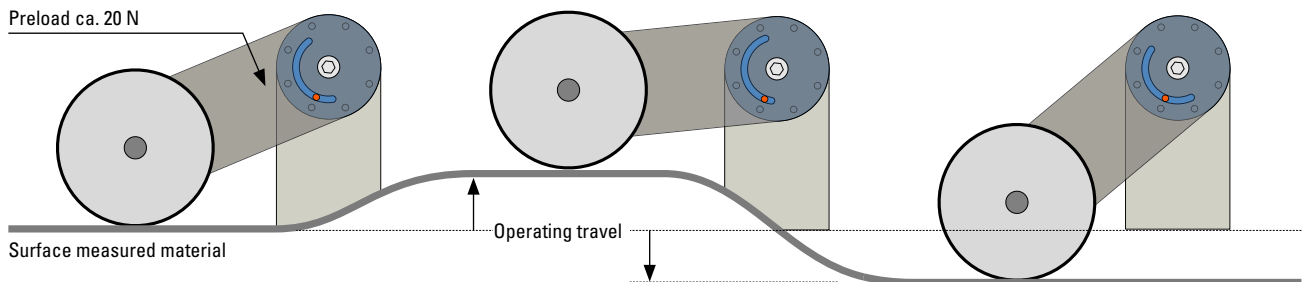

Preload

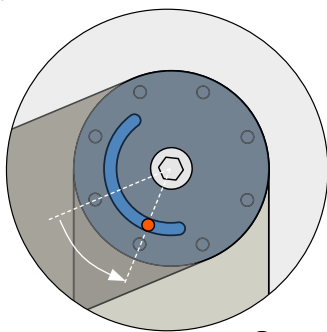

Contact force max.

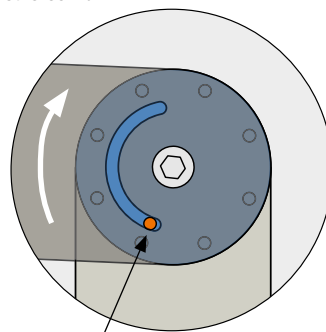

Contact force min.

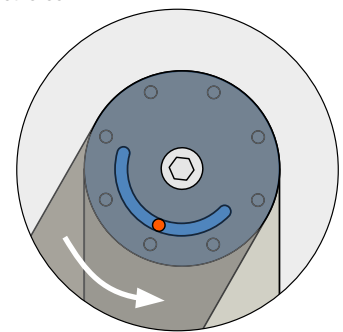

3 Spring deflection limitation

Contact force of the measuring wheel on the material to be measured

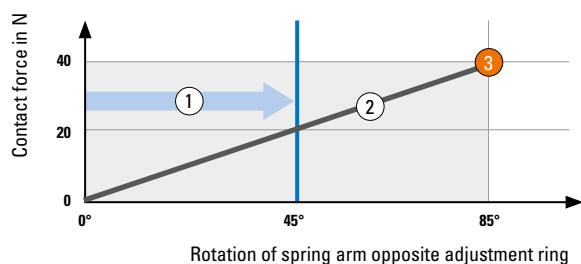

- 1 Preload (example): 20 N by turning the setting wheel by approx. 45° - corresponds to a detent point
- 2 Contact force
- 3 Spring deflection limitation to protect against overload

Measuring wheel system

Performance-Line Double measuring wheel system MWE62 With spring arm, contact force max. 40 N

Technical data

Mechanical characteristics spring arm		
Materials	spring spring bracket	spring steel aluminum
Weight	670 g	
Contact force, max.	40 N	
Operating travel, max.	80 mm	
Working temperature range	-20 °C ... +70°C [-40 °F ... +176 °F]	
Shock resistance acc. EN 60068-2-27	1000 m/s ² , 6 ms	
Vibration resistance acc. EN 60068-2-6	100 m/s ² , 55 ... 2000 Hz	

Approvals	
UL compliant acc. to	File no. E224618
CE compliant acc. to	EMV guideline 2014/30/EU RoHS guideline 2011/65/EU
UKCA compliant acc. to	EMC Regulations S.I. 2016/1091 RoHS Regulations S.I. 2012/3032

Dimensions

Dimensions in mm [inch]

Spring arm MWE60 in combination with measuring wheel and encoder KIS50

- 1 Fixing screw M4 x 6 for measuring wheel
- 2 SW5
- 3 Spring

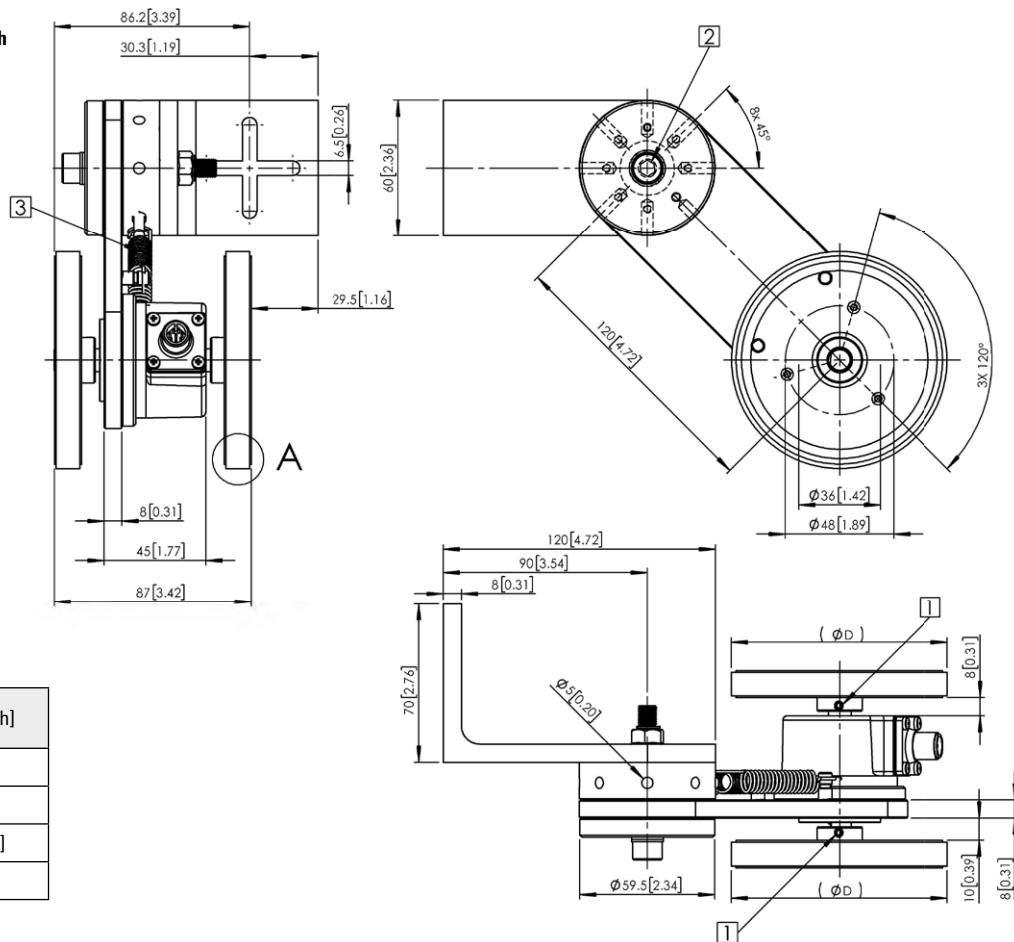

Measuring wheel circumference	ø D mm [inch]
200 mm	63.7 [2.50]
300 mm	95.54 [3.76]
500 mm	159.23 [6.26]
12"	97.07 [3.82]

A for measuring wheel with coating:

Diamond knurl (aluminum)

Plastic smooth (PU)

Tufted rubber (PU)

O-ring (NBR)

Double O-ring (NBR)

Plastic corrugated (PU)

